

SAFETY  
ENGINEERING  
FOR A SAFE  
WORK



**Safeway360**

**360.**

Catálogo  
de producto

Barreras  
flexibles

# Safeway 360

Te ofrecemos el servicio global de seguridad avanzada para **proteger a las personas de vuestros equipos de trabajo, las zonas de trabajo y los bienes materiales.**

Estamos comprometidos a darte soporte y a ofrecerte los servicios más profesionales y adecuados, con toda rapidez y seguridad.



ESTUDIO Y PROYECTO



PRODUCTO E INSTALACIÓN



POSTVENTA Y MANTENIMIENTO

Nos encargamos de resolver **todas las fases del proyecto**: desde la detección de la necesidad de solución, hasta la realización del mantenimiento de las instalaciones.

Más información

**[safeway360.com](https://safeway360.com)**

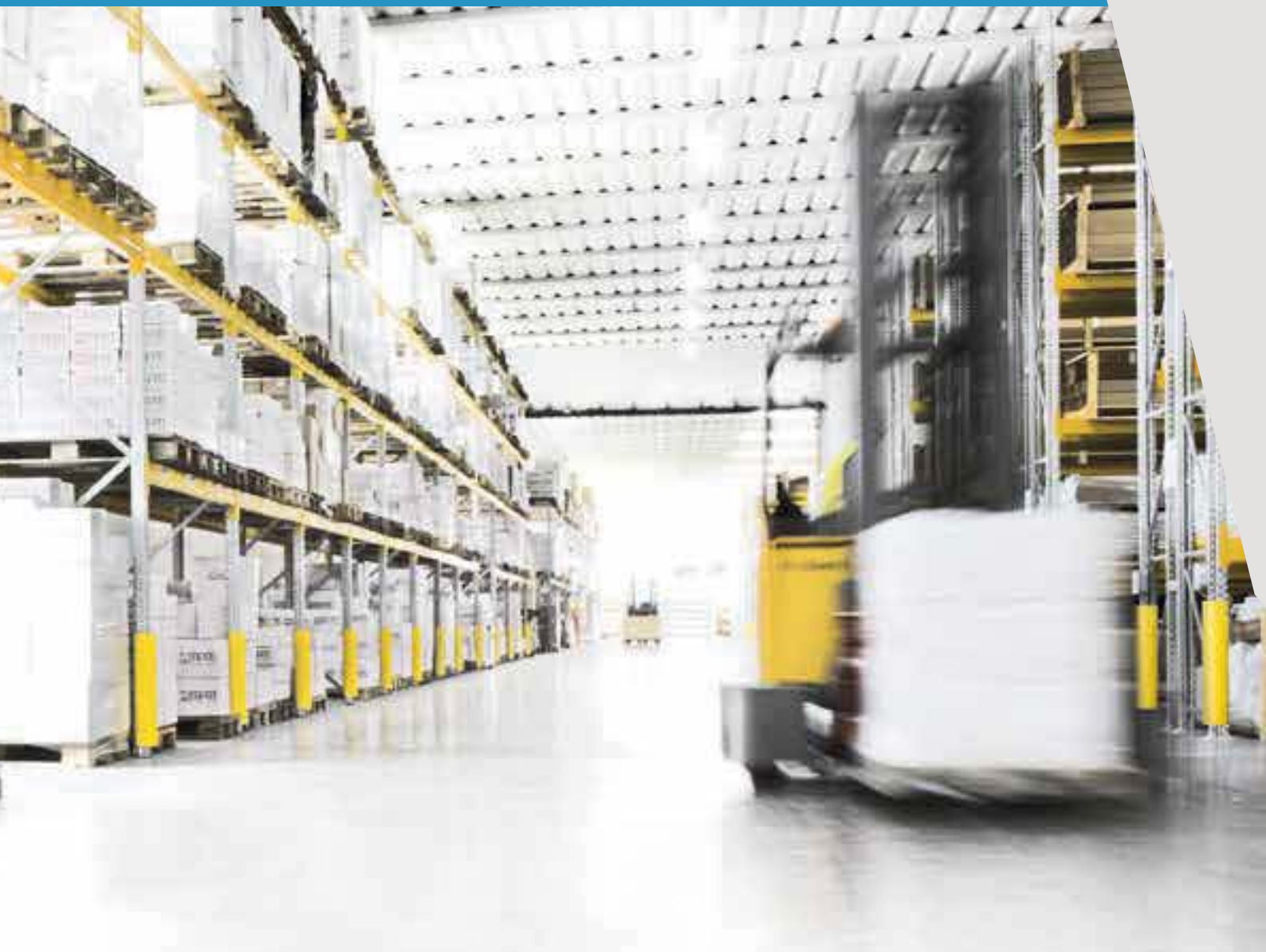

## CONTENTS

---

01	Rack Protection	page 08	09	Column Protection	page 64
02	Bollard	page 20	10	Door Frame Protections	page 72
03	Guard Rails	page 24	11	Loading Bay Protection	page 78
04	Cold Line	page 30	12	Wheel Stop	page 80
05	Pedestrian Safety Barriers	page 38	13	Cable Cover	page 84
06	Gates	page 44	14	Corner Protection	page 86
07	Link	page 50	15	Kerb	page 88
08	BFlex	page 58	16	Wall Protection	page 92

---







# **mpm** FLEXIBLE PROTECTIONS WAREHOUSE

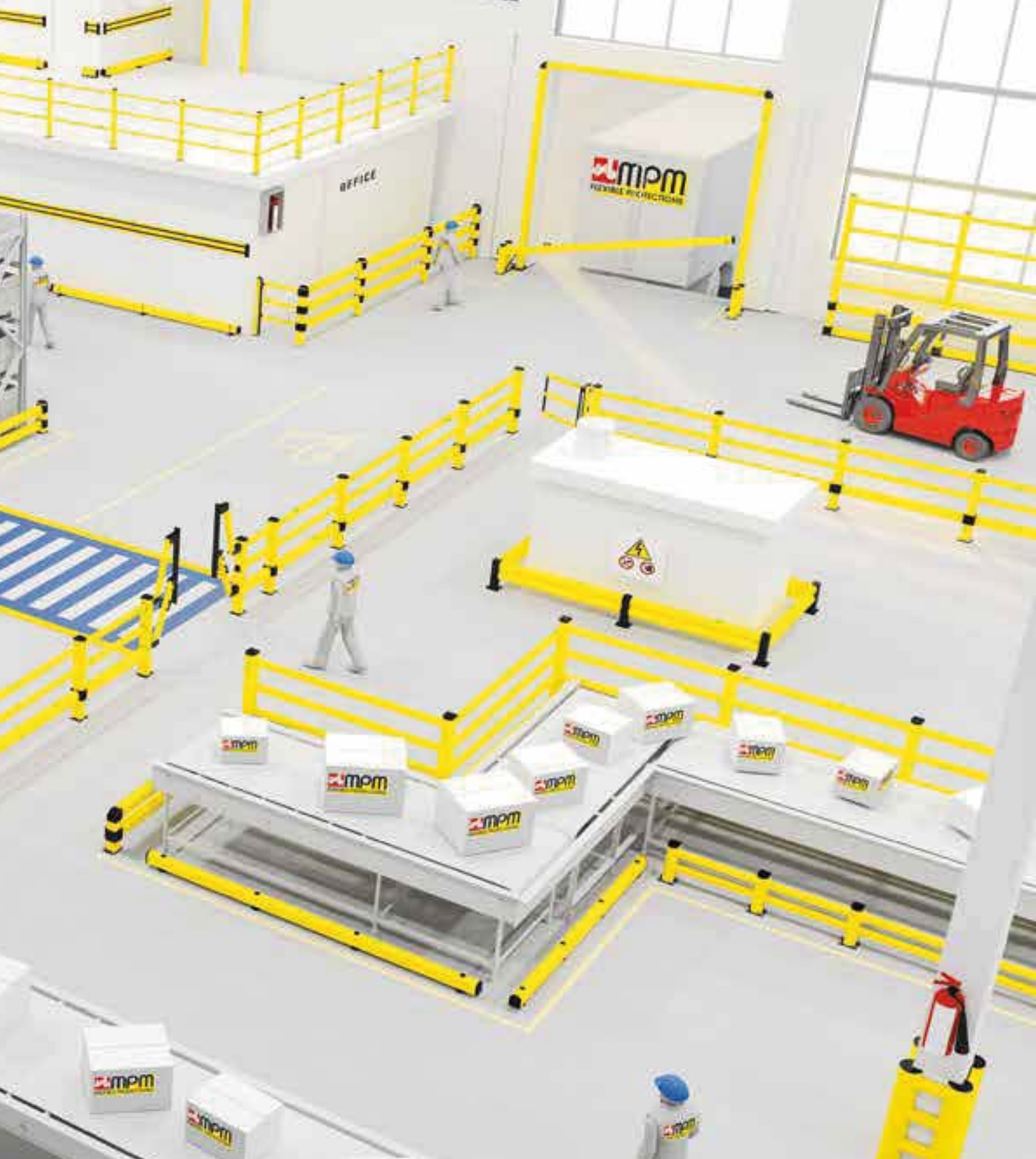

# OUR MATERIALS



## REFLEX

RESISTANT AND FLEXIBLE

## FROSTEX

RESISTANT TO LOW TEMPERATURES



RESISTANT OVER TIME

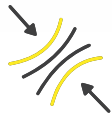

HIGH ELASTICITY



COMPLIANT WITH THE DIRECTIVE UE 2015/863 (ROHS)



100% RICYCLABLE



SELF EXTINGUISHING V0

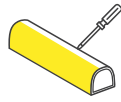

SCRATCHPROOF MATERIAL



TEMPERATURE RANGE: -30° + 50° C

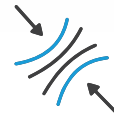

HIGH ELASTICITY



COMPLIANT WITH THE DIRECTIVE UE 2015/863 (ROHS)



100% RICYCLABLE



HB FLAMMABILITY RATING ACCORDING TO UL 94



SUITABLE FOR FOOD CONTACT



HIGH VISIBILITY AND NO PAINTING REQUIRED



EASY TO CLEAN



ROT-PROOF AND NORMALLY MILDEW-PROOF MATERIAL



HIGH VISIBILITY AND NO PAINTING REQUIRED



RESISTANT TO CHEMICALS OIL AND FUELS



ROT-PROOF AND NORMALLY MILDEW-PROOF MATERIAL



NO TOXIC



RESISTANT TO CHEMICALS OIL AND FUELS



RESISTANT TO HUMIDITY AND SALINITY



NO TOXIC



RESISTANT TO HUMIDITY AND SALINITY

RESEARCH AND DEVELOPMENT NEVER STOP!

# PIN SYSTEM

---

**PED 150 PIN**

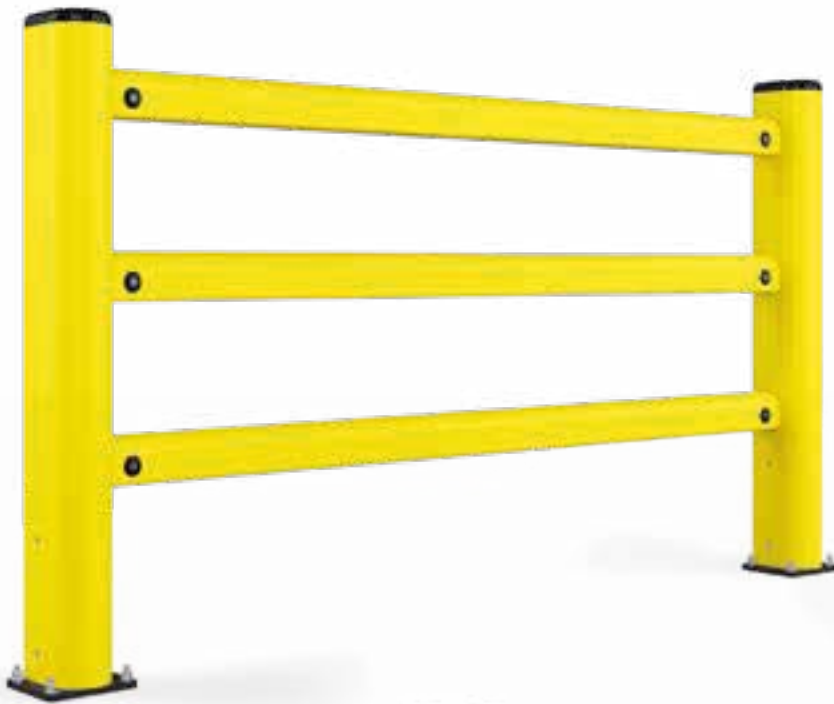

**PED 200 PIN**





# NEWS

RESEARCH AND DEVELOPMENT NEVER STOP!

## ORANGE LINE

AVAILABLE FOR:  
LM / PED 150 /  
TOWER



HIGHER  
VISIBILITY  
FOR A GREATER  
SAFETY!

## CLIP 90



EASY TO  
INSTALL

CUSTOMIZE  
YOUR BARRIER

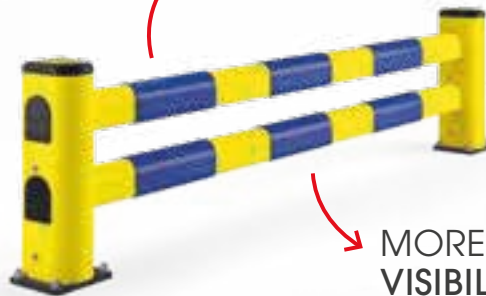

MORE  
VISIBILITY



## WORKSTATION

BIG SIZE  
UP TO 2500 x 940



DIFFERENT  
SIZES ON  
REQUEST

CUT THE RAIL AND DRILL IT  
WITH GENIUS 

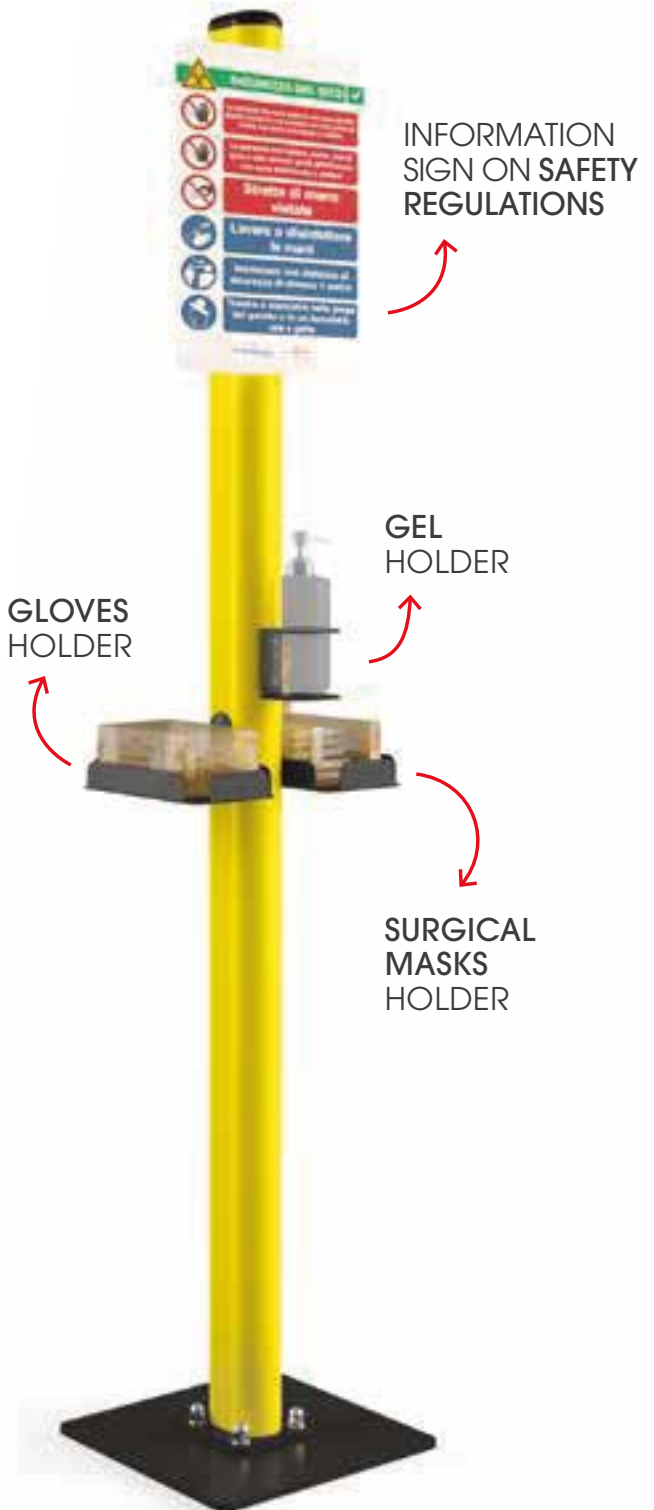

**WORLD'S UNIQUE SYSTEM!**  
YOUR CUSTOMIZED BARRIER AND HUG TOWER

AVAILABLE IN **FOUR** VERSIONS

# 01

## RACK PROTECTION OUR PROFILES FIT ALL RACKS

Full range of techno polymer profiles for protection of warehouse racks.

Gamma completa di profili in tecnopolimeri per la protezione di scaffali.

Complète gamme de profilés en tecnopolimère pour la protection d'étagères de dépôts.

Gama completa de perfiles de tecnopolímeros para las protecciones de estanterías.

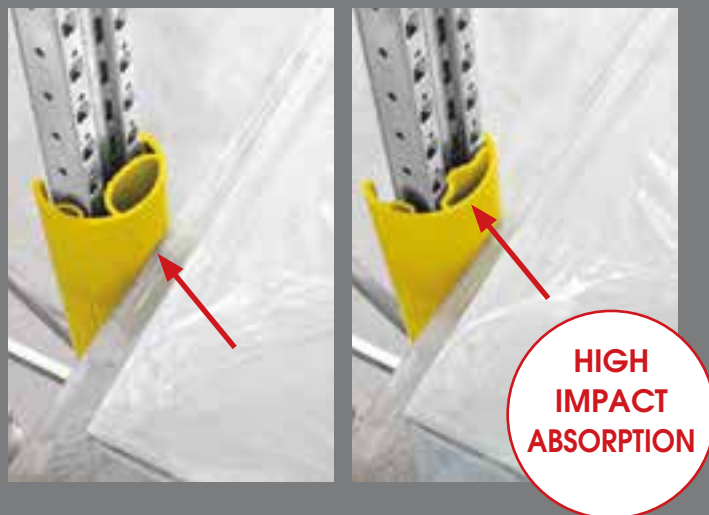

- ▶ **One big central shock absorber** in soft material to absorb front impacts.
- ▶ **Two side shock absorbers** in soft material to absorb impact during pallet placement on the rack.
- ▶ **Tested and certified to EN 15512**
- ▶ **Reduced dimensions** to keep manoeuvring spaces clear.
- ▶ **Interlocking system** with practical click-fit tools.
- ▶ **Rigid outer cladding, scratch-resistant** and easy to clean.





# RPS / RPM / RPL



**EASY TO INSTALL**

**THE ONLY ONE WITH TRIPLE SHOCK ABSORBER**



**CUSTOMIZED SOLUTIONS TO FIT ALL UPRIGHTS**



**RPS 600**



Small

Available also size 400

Packing 6 pz / box  
Packing 115 pz / big parcel  
Colour **M**



**RPM 600**



Medium

Available also size 400

Packing 4 pz / box  
Packing 80 pz / big parcel  
Colour **M**



**RPL 600**



Large

Available also size 400

Packing 2 pz / box  
Packing 52 pz / big parcel  
Colour **M**



**RPL XL 600**



Extra Large

Available also size 400

Packing to be defined  
Colour **M**



**RP CLICK**

Packing 1 pz / box

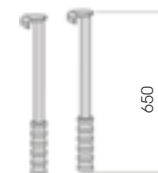

# RACK CORNER

ANTISHOCK  
MATERIAL  
INSIDE

FAST  
AND EASY  
TO INSTALL

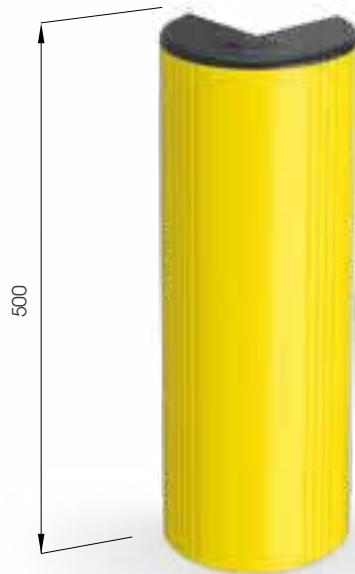

## RACK CORNER

Packing Colour **to be defined**  
M

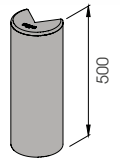

Equipped with accessories



SM



DIFFERENT SIZES ON REQUEST

FAST AND EASY TO INSTALL



M12 GALVANISED STEEL



SM 1100x400

Length **1.100**  
Packing **unpacked on pallet**  
Colour **B M**

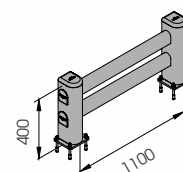

Equipped with accessories



SM 1500x400 MODULAR

Packing **unpacked on pallet**  
Colour **B M**

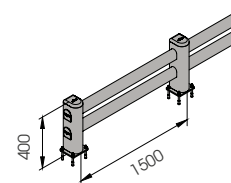

Equipped with accessories





# Rack end Barriers

LM



DIFFERENT SIZES ON REQUEST

FAST AND EASY TO INSTALL



M12 GALVANISED STEEL



LM 1100x500  
2400x500

Length 1.100 / 2.400 mm  
Packing unpacked on pallet  
Colour B M

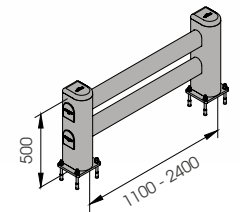

Equipped with accessories



LM 2000x500 MODULAR

Packing unpacked on pallet  
Colour B M

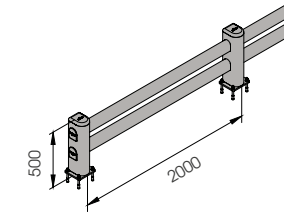

Equipped with accessories



**NEW**

Rack end Barriers

# LM/1 LINK



**DIFFERENT SIZES ON REQUEST**



**M12 GALVANISED STEEL**



**LM/1 LINK 1100x500  
2400x500**

Length **1.100 / 2.400 mm**  
Packing **unpacked on pallet**  
Colour **B M**

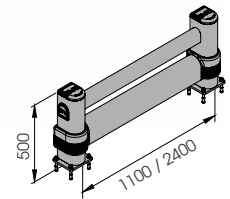

Equipped with accessories



**LM / 1 LINK 2000x500  
MODULAR**

Packing **unpacked on pallet**  
Colour **B M**

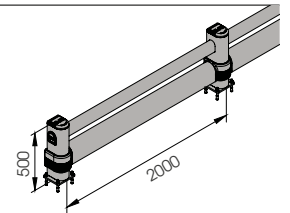

Equipped with accessories



# LINK SINGLE RE



DIFFERENT SIZES ON REQUEST

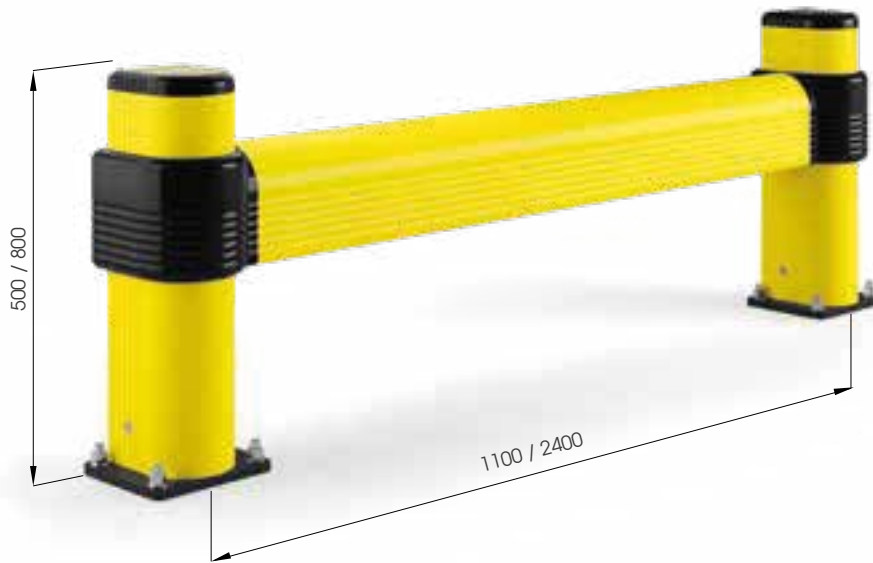

M12 GALVANISED STEEL



**LINK SINGLE RE 1100x500**  
**1100x800**  
**2400x500**  
**2400x800**

Length 1.100 / 2.400 mm  
 Packing unpacked on pallet  
 Colour B M

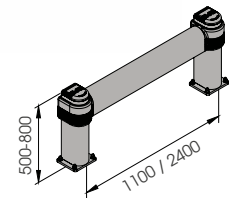

Equipped with accessories

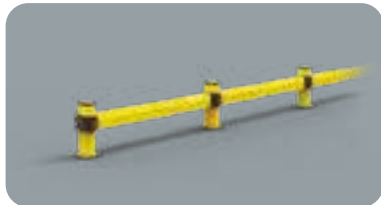

**LINK SINGLE 2000x500 MODULAR**  
**LINK SINGLE 2000x800 MODULAR**

Packing unpacked on pallet  
 Colour B M

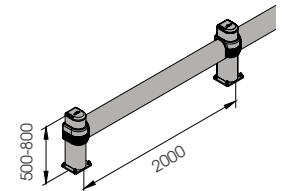

Equipped with accessories





# LINK LM RE



DIFFERENT SIZES ON REQUEST



M12 GALVANISED STEEL



**LINK LM RE** 1100x500  
1100x800  
2400x500  
2400x800

Length 1.100 / 2.400 mm  
Packing unpacked on pallet  
Colour **B** **M**

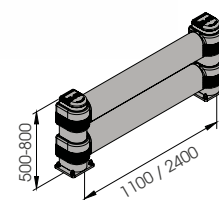

Equipped with accessories



**LINK LM 2000x500 MODULAR**  
**LINK LM 2000x800 MODULAR**

Packing unpacked on pallet  
Colour **B** **M**

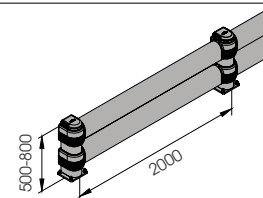

Equipped with accessories



# Rack end Barriers

## FENCE 90



DIFFERENT SIZES ON REQUEST

FAST AND EASY TO INSTALL



M12 GALVANISED STEEL



FE 90 1100x400

Length 1.100 mm  
Packing unpacked on pallet  
Colour B M

Equipped with accessories

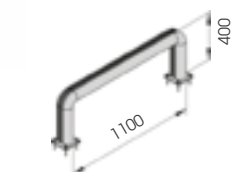

FE 90 2400x400

Length 2.400 mm  
Packing unpacked on pallet  
Colour B M

Equipped with accessories

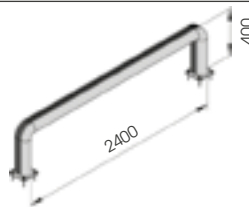

# FENCE 150



DIFFERENT SIZES ON REQUEST

FAST AND EASY TO INSTALL



**M12 GALVANISED STEEL**



**FE 150 1100x550**

Length **1.100 mm**  
Packing **unpacked on pallet**  
Colour **B M**

Equipped with accessories



**FE 150 2400x550**

Length **2.400 mm**  
Packing **unpacked on pallet**  
Colour **B M**

Equipped with accessories





# FENCE 150 REINFORCED



**DIFFERENT SIZES ON REQUEST**

**FAST AND EASY TO INSTALL**



**M12 GALVANISED STEEL**



**FE 150 REF 1100x550**

Length **1.100 mm**  
 Packing **unpacked on pallet**  
 Colour **B M**



Equipped with accessories



**FE 150 REF 2400x550**

Length **2.400 mm**  
 Packing **unpacked on pallet**  
 Colour **B M**



Equipped with accessories



# FENCE LINK



DIFFERENT SIZES ON REQUEST

FAST AND EASY TO INSTALL



M12 GALVANISED STEEL



FE LINK 1100x550

Length 1.100 mm  
Packing unpacked on pallet  
Colour B M

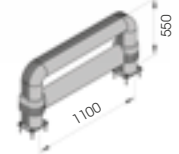

Equipped with accessories



FE LINK 2400x550

Length 2.400 mm  
Packing unpacked on pallet  
Colour B M

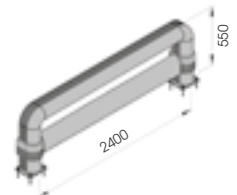

Equipped with accessories



# 02

## BOLLARD

Designed to protect access to gates or big doors from huge traffic or simply to mark restricted areas for pedestrians.  
Fully equipped with fixing accessories.

Ideato per proteggere l'accesso a cancelli o portoni dalla movimentazione di mezzi pesanti o semplicemente per impedire l'ingresso di pedoni. Provisto di accessori di fissaggio.

Étudié pour protéger l'accès aux portes ou entrées de grand trafic ou simplement pour marquer les zones de passage piétons. Equipé avec les accessoires d'installation.

Diseñado para proteger el acceso a puertas o portones del movimiento de vehículos pesados o simplemente para evitar la entrada de peatones. Provisto de accesorios de fijación.





GRD 90



FAST AND EASY TO INSTALL



M12 GALVANISED STEEL



GRD 90 250

Packing Colour **unpacked on pallet**

**B** **M**

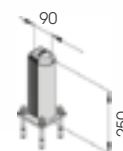

Equipped with accessories



# Bollard

## GRD 150



FAST  
AND EASY  
TO INSTALL



M12  
GALVANISED STEEL



GRD 150 500  
800  
1150

Packing  
Colour **unpacked on pallet**

B M

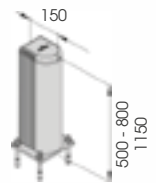

Equipped with accessories



# GRD 200

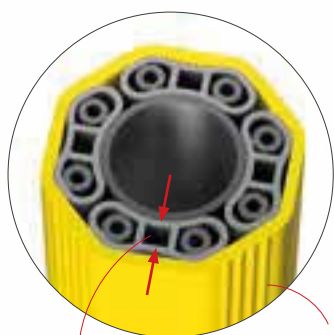

**FLEXIBLE**

**NEW  
ANTISHOCK  
BUMPER**

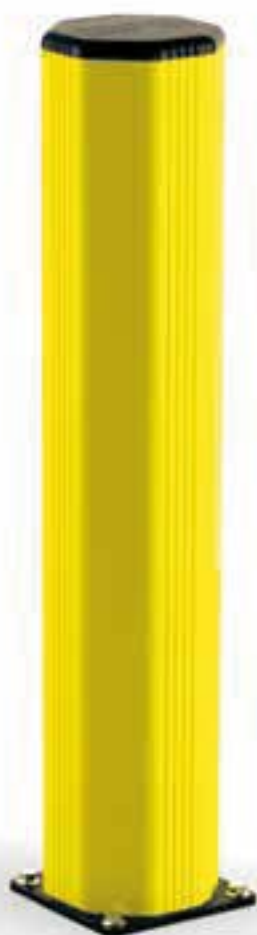

**INCLUDED**

**FAST  
AND EASY  
TO INSTALL**



**S16  
GALVANISED STEEL**



**GRD 200 1200  
2000**

Packing **unpacked on pallet**  
Colour **M**



Equipped with accessories





# 03

## GUARD RAILS

A new bumper system specific for the protection of the walls resistant against trolleys movements. Designed by following an innovative technical design that combines speed and simplicity in the steps of installation and cleaning. Available in different lengths.

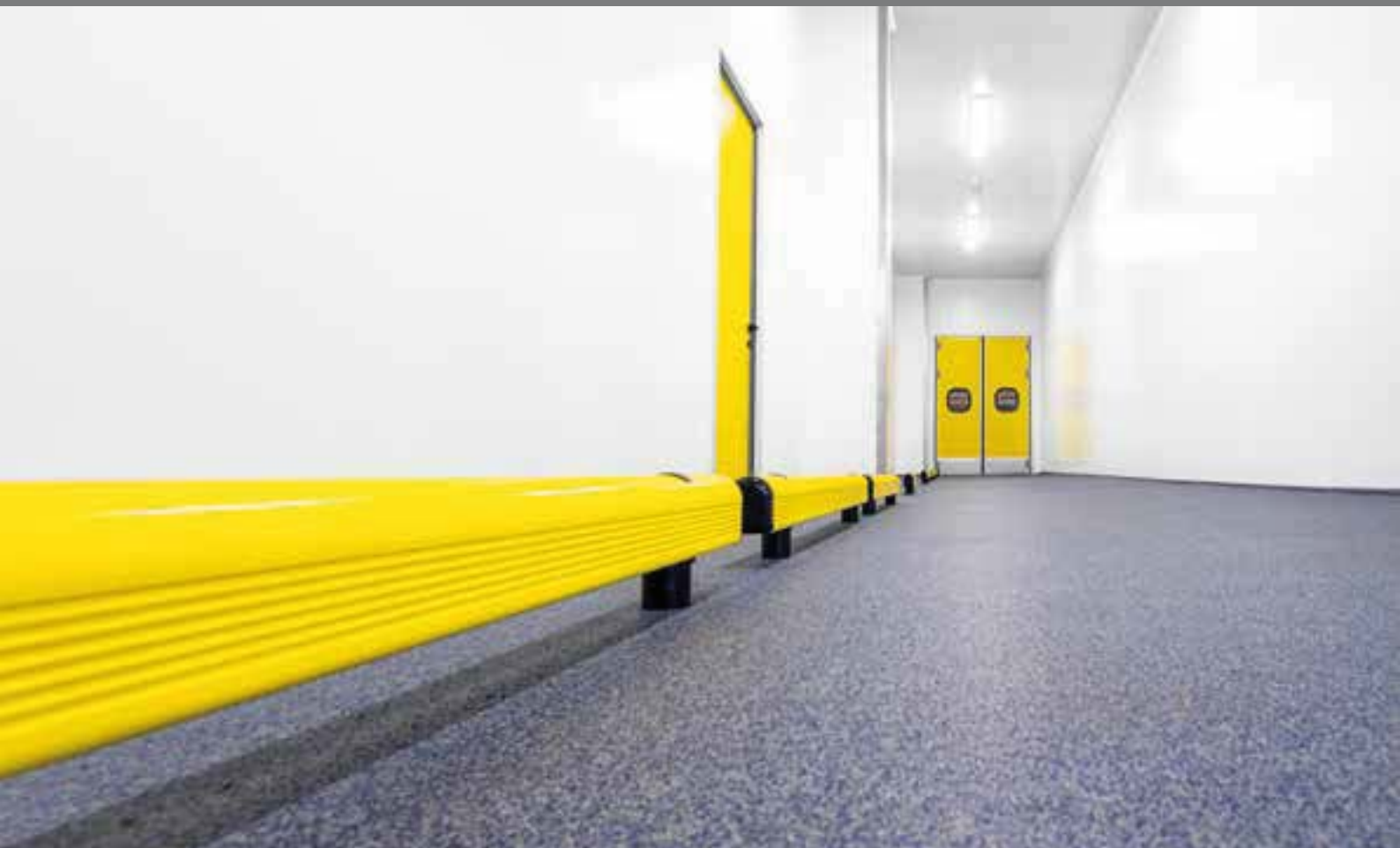

Sistema profili antiurto specifico per la protezione delle pareti dai carrelli in movimento. Progettato seguendo un innovativo disegno tecnico che coniuga rapidità e semplicità nelle fasi di installazione e pulizia. Disponibile in diverse lunghezze.

Nouveau système bumper, spécifique pour protéger les murs contre les mouvements des charriots. Étudié avec un modern dessin qui regroupe la rapidité et la facilité pendant l'installation et le nettoyage. Disponible en différents longueurs.

Sistema de perfiles anti-impacto específico para la protección de las paredes de los carros en movimiento. Diseñado según un diseño técnico innovador que une velocidad y simplicidad en las fases de instalación y limpieza. Disponible en diferentes longitudes.



# Guard Rails

## GUARD RAIL 90



**QUICK  
INSTALLATION  
WITH  
EXPANSION  
SCREW**



**M16  
GALVANISED STEEL**



**ALTERNATIVE FIXING**  
HIGH RESISTANCE WITH RESIN

**SF16  
STAINLESS STEEL**



**GR 90** 500  
750  
1000  
1500

Length 500 mm  
Packing unpacked on pallet

Length 750 / 1000 / 1500 mm  
Packing 2 pz / box

Colour  B  M

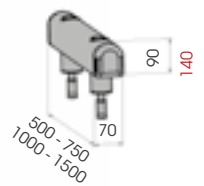

**GR 90** 2000  
3000  
4000

Length 2.000 / 3.000 / 4.000 mm  
Packing unpacked on pallet  
Colour  B  M

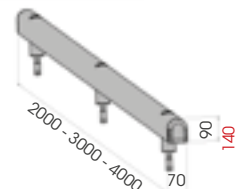

Equipped with accessories





# GUARD RAIL 150



**HIGH RESISTANCE WITH RESIN**



**SF20 STAINLESS STEEL**



**GR 150** 500  
750  
1000  
1500

Length 500 / 750 / 1000 / 1500 mm  
Packing unpacked on pallet  
Colour  B  M

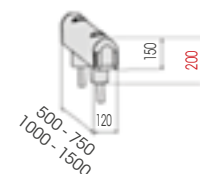

Equipped with accessories



**GR 150** 2000  
3000  
4000

Length 2.000 / 3.000 / 4.000 mm  
Packing unpacked on pallet  
Colour  B  M

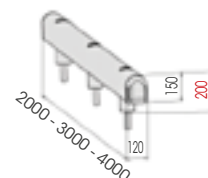

Equipped with accessories



# GRIN 90

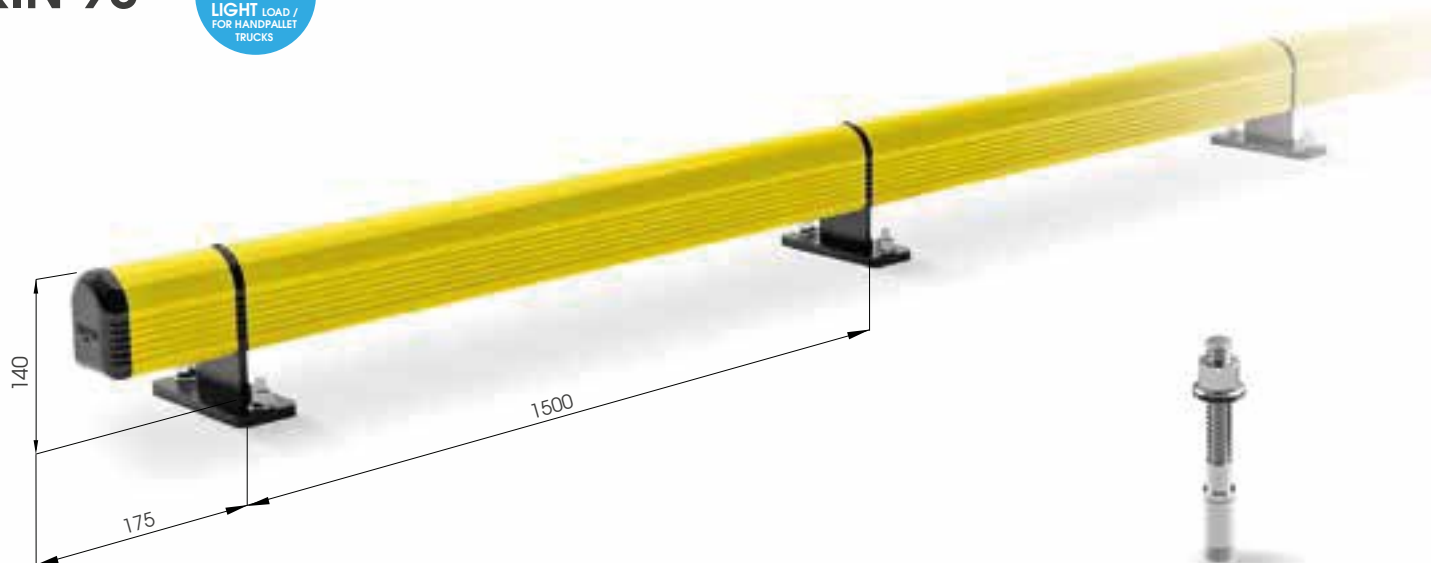

**M12  
GALVANISED STEEL**



**GRIN 90 1500**

Length **1500 mm**  
Packing **to be defined**  
Colour **M**

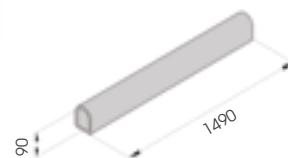

**GRINCO 90**

Packing **to be defined**  
Colour **M**



Equipped with accessories



**GRINT 90**

Packing **to be defined**  
Colour **M**



Equipped with accessories



# GRIN 150



**M12  
GALVANISED STEEL**



**GRIN 150 2000**

Length **2000 mm**  
Packing **to be defined**  
Colour **M**

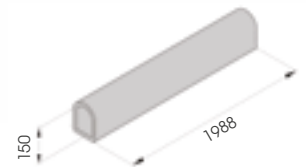

**GRINCO 150**

Packing **to be defined**  
Colour **M**



Equipped with accessories



**GRINT 150**

Packing **to be defined**  
Colour **M**



Equipped with accessories





# 04

## COLD LINE

Specific solutions for the protection of areas at risk of impact, in environments with negative temperature. They are suitable to protect corners, entrances, gates, panels and cold rooms walls.



Soluzioni specifiche per la protezione di zone a rischio d'impatto in ambienti a temperatura negativa.

Ideali per proteggere angoli sporgenti, accessi e portoni, pannelli e pareti di celle frigorifere.

Solutions spécifiques pour la protection des zones à risque de collision dans les environnements à température négative.

Idéal pour protéger les angles, les entrées et les portes, les panneaux et les murs des chambres froides.

Soluciones específicas para proteger las zonas con riesgo de impacto en entornos de temperatura negativa.

Son ideales para proteger esquinas, entradas y puertas, paneles y paredes de las cámaras frigoríficas.



**-30°**

RESISTANT  
TO LOW  
TEMPERATURES

**FROSTEX**  
RESISTANT TO LOW TEMPERATURES



# ROD 70



**REMOVABLE**  
EASY TO  
REMOVE AND  
TO REPLACE

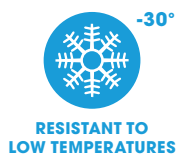

**M20  
GALVANISED STEEL**

**Fixing accessory available also in stainless steel**



**ROD 70 266**

Packing Colour **1 pz / box**  
**M**

**Drill Ø 38**  
Equipped with accessories

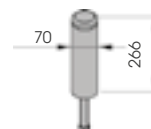



# ROD 120



**REMOVABLE**  
EASY TO REMOVE AND TO REPLACE

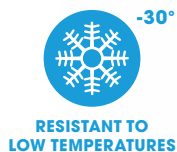

Fixing accessory available also in stainless steel



**ROD 120 433  
560  
800**

Drill  $\varnothing$  56  
Equipped with accessories

Packing Colour **1 pz / bag**  
**M**

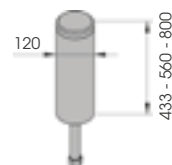

# ROD FLOOR 70



**QUICK  
INSTALLATION  
WITH  
EXPANSION  
SCREW**



**M16  
GALVANISED STEEL**



**RESISTANT TO  
LOW TEMPERATURES**



**RF 70 500  
1000  
1500**

Length **500 / 1000 / 1500 mm**  
Packing **unpacked on pallet**  
Colour **M**

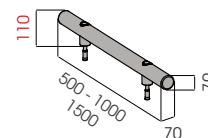

Equipped with accessories



**RF 70 2000  
3000**

Length **2.000 / 3.000 mm**  
Packing **unpacked on pallet**  
Colour **M**

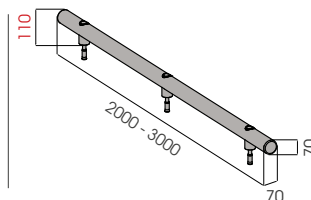

Equipped with accessories



# ROD FLOOR 120



**SF20  
STAINLESS STEEL**

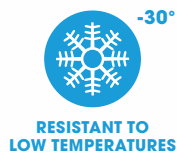

**RF 120** 500  
1000  
1100  
1500

Length 500 / 1000 / 1100 / 1500 mm  
Packing unpacked on pallet  
Colour **M**

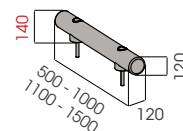

Equipped with accessories



**RF 120** 2000  
2500  
3000

Length 2.000 / 2.100 / 3.000 mm  
Packing unpacked on pallet  
Colour **M**

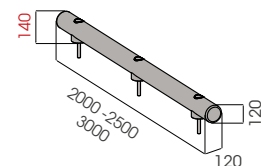

Equipped with accessories





# ROD FLOOR 120 DOUBLE RE



SF20 x 450  
STAINLESS STEEL



NOT SHARP EDGES



RESISTANT TO  
LOW TEMPERATURES



RF 120 DOUBLE 1100

Length 1100 mm  
Packing unpacked on pallet  
Colour M

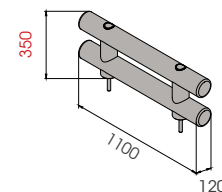

Equipped with accessories



RF 120 DOUBLE 2500

Length 2.500 mm  
Packing unpacked on pallet  
Colour M

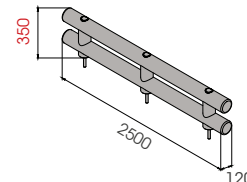

Equipped with accessories



# ROD FLOOR 120 DOUBLE



SF20 x 450  
STAINLESS STEEL

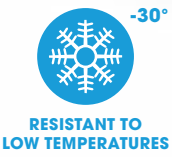
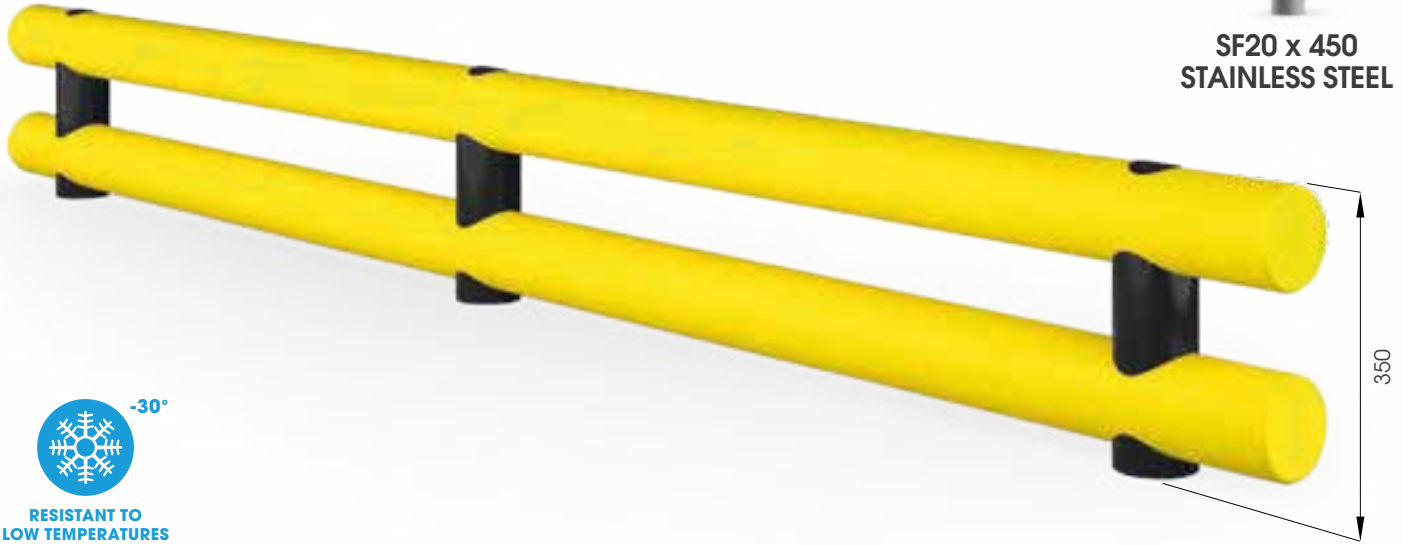

**RF 120 DOUBLE** 500  
1000  
1500

Length 500 / 1000 / 1500 mm  
Packing unpacked on pallet  
Colour **M**

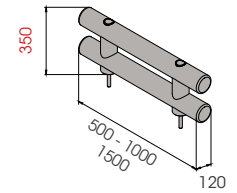

Equipped with accessories



**RF 120 DOUBLE** 2000  
3000

Length 2.000 / 3.000 mm  
Packing unpacked on pallet  
Colour **M**

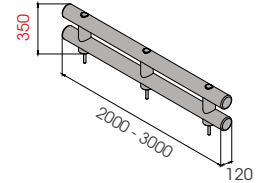

Equipped with accessories



# 05

## PEDESTRIAN SAFETY BARRIERS

A new protection system specific for the protection of pedestrians and resistant to trolleys movements with different load types. Designed by following an innovative technical design that combines speed and simplicity in the steps of installation and cleaning. Available in different lengths.

Sistema di profili antiurto specifico per la protezione delle aree pedonali dai carrelli in movimento con diverse portate di carico. Progettato seguendo un innovativo disegno tecnico che coniuga rapidità e semplicità nelle fasi di installazione e pulizia. Disponibile in diverse lunghezze.

Nouveau système bumper, spécifique pour protéger les zones piétonnes contre les mouvements des charriots. Étudié avec un modern dessin qui regroupe la rapidité et la facilité pendant l'installation et le nettoyage. Disponible en différents longueurs.

Sistema específico de perfiles antichoque para la protección de zonas peatonales de carros en movimiento con diferentes capacidades de carga. Diseñado según un diseño técnico innovador que une velocidad y simplicidad en las fases de instalación y limpieza. Disponible en diferentes longitudes.





# HAND RAIL 90



**FAST AND EASY TO INSTALL**

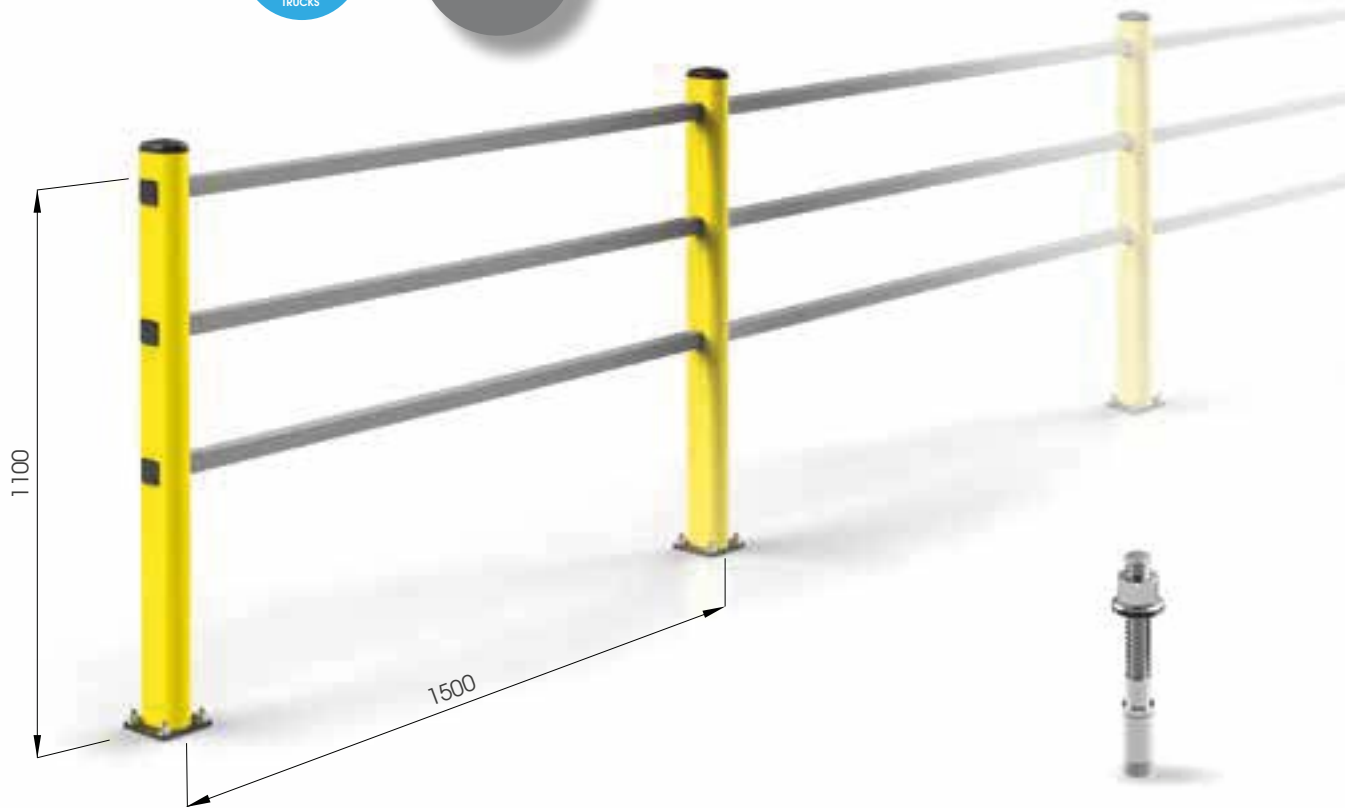

**M12 GALVANISED STEEL**



**HR 90 1500x1150 MODULAR**

Packing Colour **unpacked on pallet**  
M

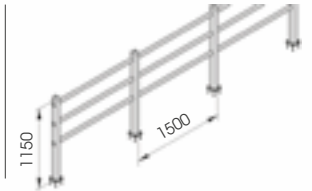

Equipped with accessories

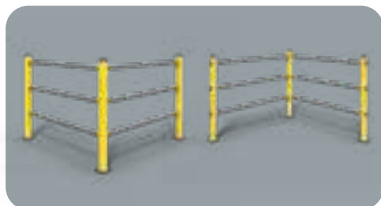

**HR 90 1500x1150 CORNER**

Packing Colour **unpacked on pallet**  
M

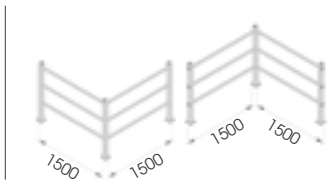

Equipped with accessories



# PEDESTRIAN 90



**FAST AND EASY TO INSTALL**



**M12 GALVANISED STEEL**



**PED 90 1500x1150 MODULAR**

Packing Colour **unpacked on pallet**  
 B  M



Equipped with accessories

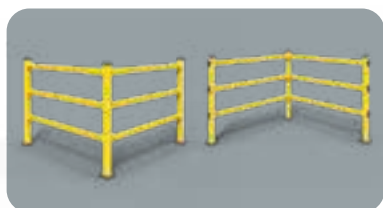

**PED 90 1500x1150 CORNER**

Packing Colour **unpacked on pallet**  
 B  M

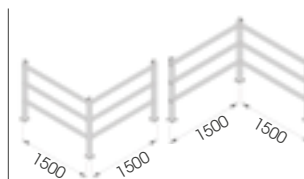

Equipped with accessories



# PEDESTRIAN 150



FAST AND EASY TO INSTALL



**M12 GALVANISED STEEL**



**PED 150 2000x1150 MODULAR**

Packing Colour **unpacked on pallet**  
 B  M

Equipped with accessories

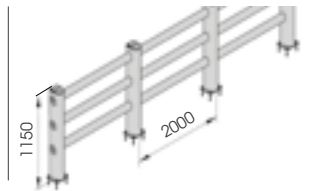

**PED 150 2000x1150 CORNER**

Packing Colour **unpacked on pallet**  
 B  M

Equipped with accessories

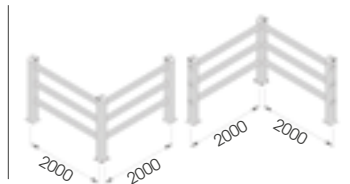



# PEDESTRIAN 90 REINFORCED



**M12 GALVANISED STEEL**



**PED 90 REF MODULAR**

Packing **unpacked on pallet**

Colour **B** **M**

Equipped with accessories

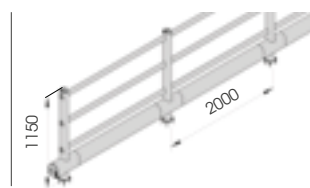

# PEDESTRIAN 150 LINK



FAST AND EASY TO INSTALL



**PED 150 LINK**

**External Corners available**

Equipped with accessories

Packing Colour **unpacked on pallet**



# 06

## GATES

Safety gate system with different opening possibilities, ideated to be installed on our pedestrian barriers. Designed by following an innovative technical design that combines speed and simplicity in the steps of installation and cleaning. Available in different opening systems.





Sistema di cancelli antiurto ideati per l'installazione nelle nostre barriere di protezione per aree pedonali. Progettati seguendo un innovativo disegno tecnico che coniuga rapidità e semplicità nelle fasi di installazione e pulizia. Disponibili molteplici sistemi di apertura.

Système de portillons résistant aux chocs étudié pour l'installation de nos barrières de protections pour les zones piétons. Portillons conçus suivant un design innovant qui combine rapidité et simplicité pendant le montage et le nettoyage. Différents systèmes d'ouvertures disponibles.

Sistema de puertas antigolpe diseñadas para la instalación de nuestras barreras de protección para áreas peatonales. Diseñado según un diseño técnico innovador que une velocidad y simplicidad en las fases de instalación y limpieza. Están disponibles varios sistemas de apertura.



# DOOR PEDESTRIAN 90

**DIFFERENT SIZES ON REQUEST**



**DP 90 ONE WAY**

Packing Colour **to be defined**  
M P

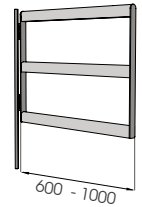

Equipped with accessories

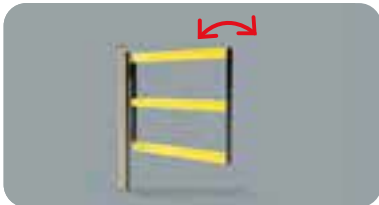

**DP 90 SWING**

Packing Colour **to be defined**  
M P



Equipped with accessories

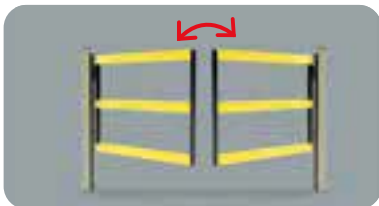

**DP 90 SWING DOUBLE**

Packing Colour **to be defined**  
M P

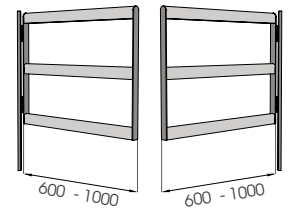

Equipped with accessories



# DOOR PEDESTRIAN 150

DIFFERENT SIZES ON REQUEST

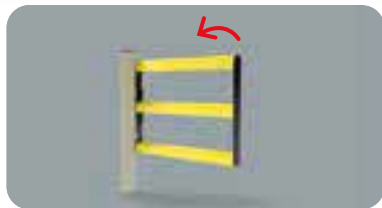

**DP 150 ONE WAY**

Packing Colour **to be defined**  
M P

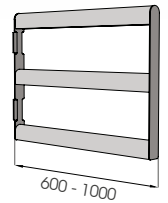

Equipped with accessories

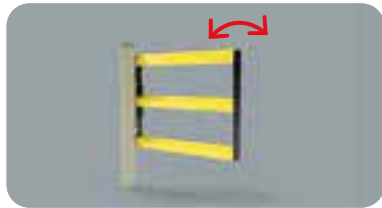

**DP 150 SWING**

Packing Colour **to be defined**  
M P

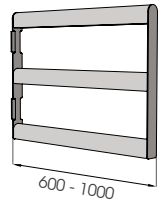

Equipped with accessories

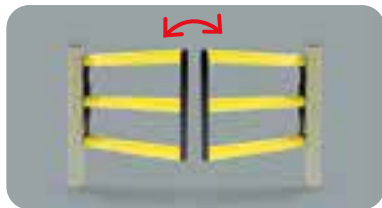

**DP 150 SWING DOUBLE**

Packing Colour **to be defined**  
M P

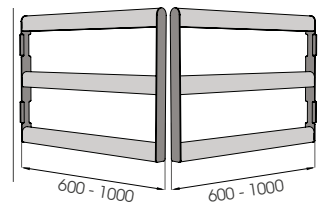

Equipped with accessories





# LIFT GATE 90

DIFFERENT SIZES ON REQUEST

NEW

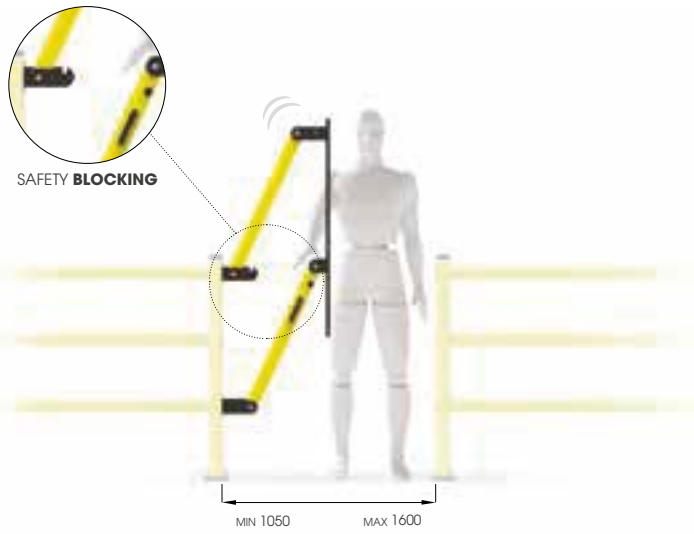

# LIFT GATE 90 DOUBLE



DOUBLE GATE

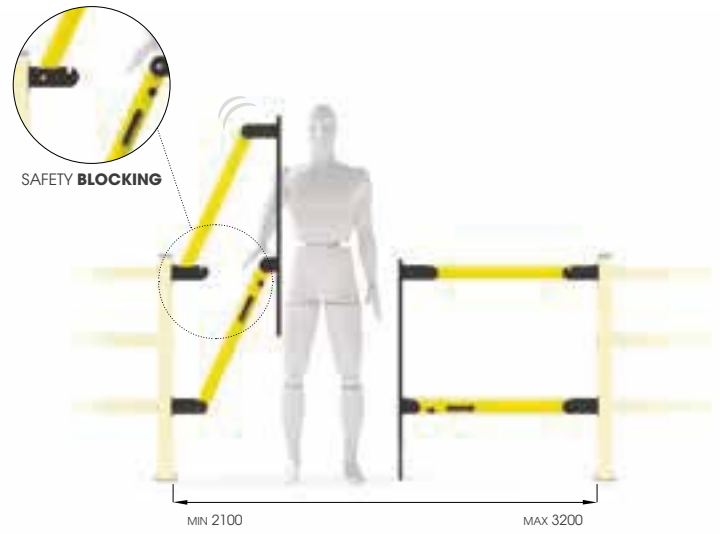

LIFT GATE 90

Packing Colour **to be defined**  
M P

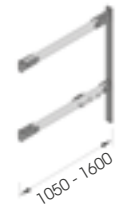

Equipped with accessories

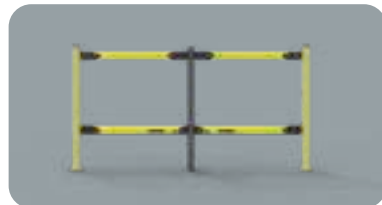

LIFT GATE 90 DOUBLE

Packing Colour **to be defined**  
M P

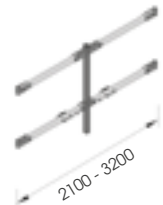

Equipped with accessories



# LIFT GATE 150

DIFFERENT SIZES ON REQUEST

NEW

# LIFT GATE 150 DOUBLE

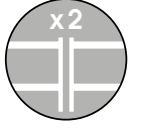

DOUBLE GATE

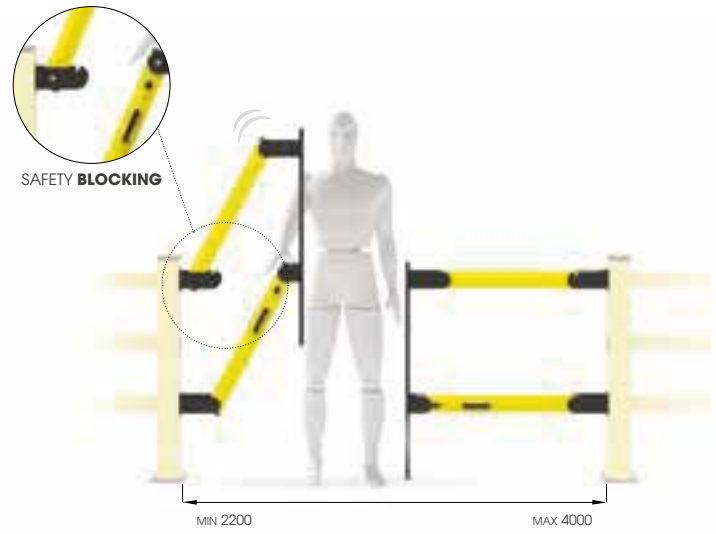
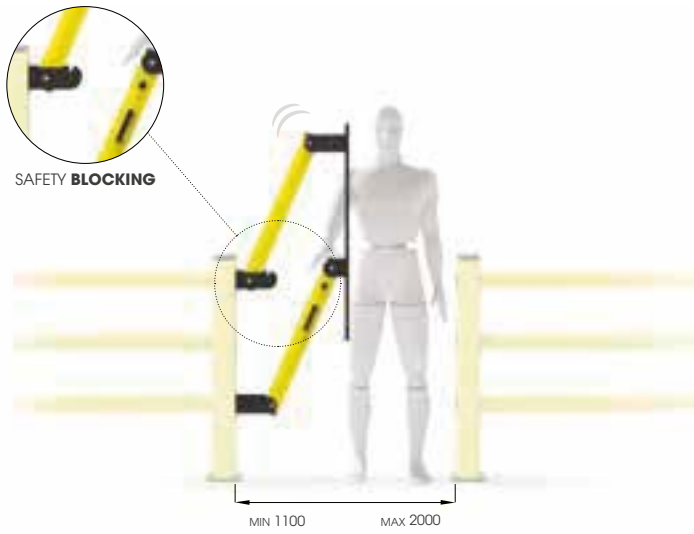

LIFT GATE 150

Packing Colour **to be defined**  
M P

Equipped with accessories



LIFT GATE 150 DOUBLE

Packing Colour **to be defined**  
M P

Equipped with accessories

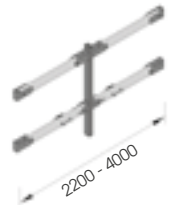

# 07

## LINK

The first adaptable barrier in the world thanks to the new connection system. Rail adjustable height, easy to set up, higher resistance in the most critical points.

Prima barriera al mondo regolabile a piacimento con nuovo sistema di raccordo. Altezza regolabile, facilmente componibili e resistenza potenziata nei punti piu' critici.

Première barrière au monde à modifier aux besoins avec un nouveau système de jonction. Hauteur à changer, facile à assembler et résistance renforcée aux points plus compliqués.

Primera barrera del mundo ajustable según lo necesario con un nuevo sistema de ajuste. Altura ajustable, fácilmente componibles y resistencia potenciada en los puntos más críticos.

**NEW  
PRODUCT**



**ADAPTABLE  
HEIGHT**



**ON YOUR  
NEEDS**

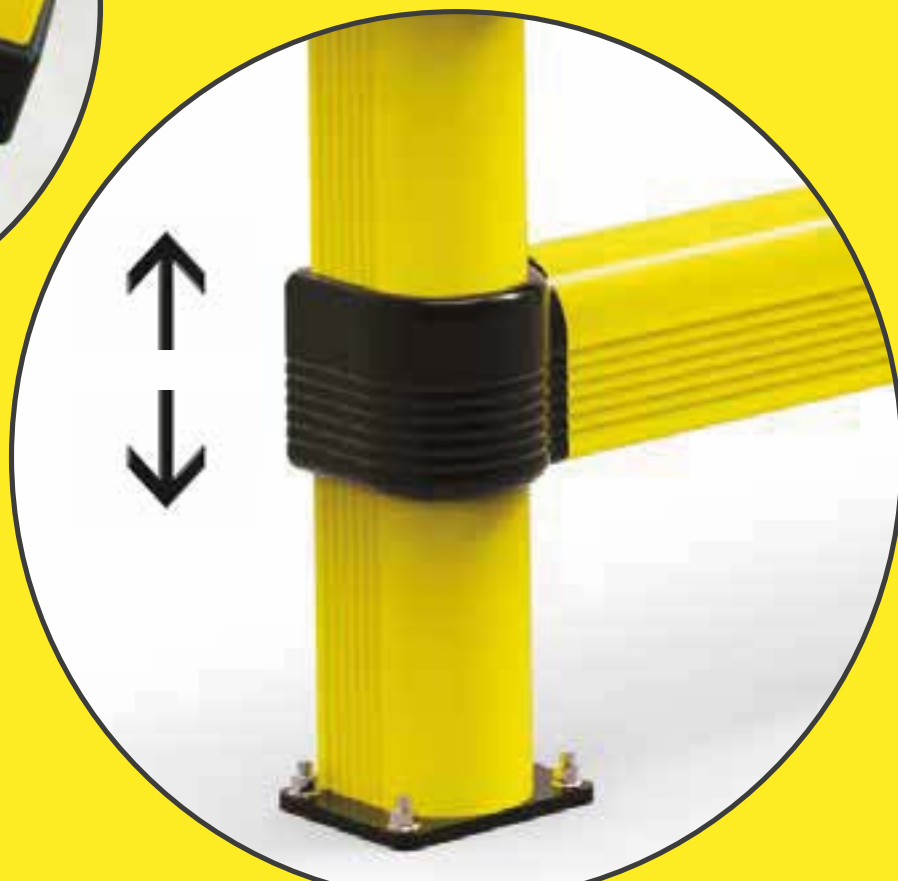



# LINK 150/3



DIFFERENT SIZES ON REQUEST



M12 GALVANISED STEEL



LINK 150/3

Packing Colour **unpacked on pallet**  
B M

Equipped with accessories

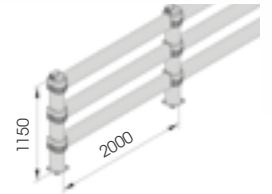

LINK 150/3 CORNER

Packing Colour **unpacked on pallet**  
B M

External Corners available

Equipped with accessories

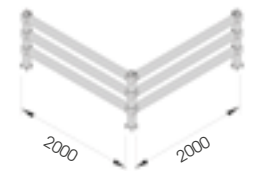

Link

# LINK 150/2



DIFFERENT SIZES ON REQUEST



M12 GALVANISED STEEL



LINK 150/2

Packing Colour **unpacked on pallet**  
B M

Equipped with accessories

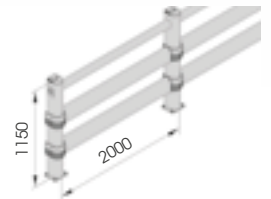

LINK 150/2 CORNER

Packing Colour **unpacked on pallet**  
B M

External Corners available

Equipped with accessories

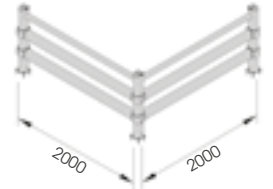

# LINK 150/1



DIFFERENT SIZES ON REQUEST



M12 GALVANISED STEEL



LINK 150/1

Packing Colour **unpacked on pallet**  
B M

Equipped with accessories

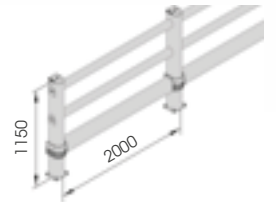

LINK 150/1 CORNER

Packing Colour **unpacked on pallet**  
B M

External Corners available

Equipped with accessories

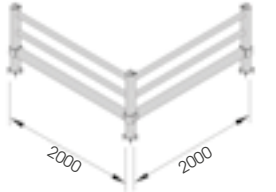



Link

# LINK LM



DIFFERENT SIZES ON REQUEST



M12 GALVANISED STEEL

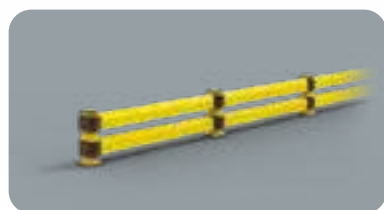

LINK LM 500 800

Packing Colour **unpacked on pallet**  
B M

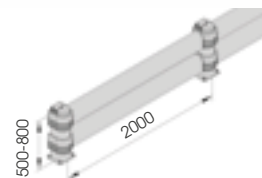

Equipped with accessories



LINK LM CORNER

Packing Colour **unpacked on pallet**  
B M

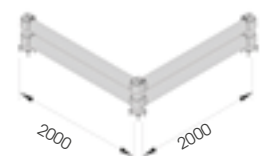

External Corners available

Equipped with accessories



# LINK SINGLE



DIFFERENT SIZES ON REQUEST

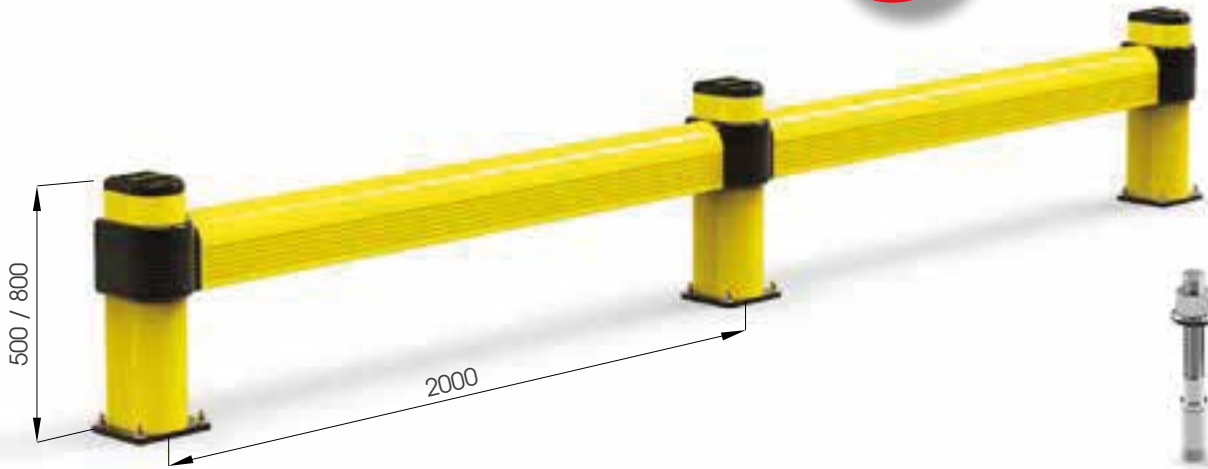

M12 GALVANISED STEEL

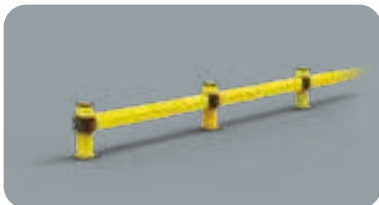

LINK SINGLE 500 800

Equipped with accessories

Packing Colour **unpacked on pallet**  
B M

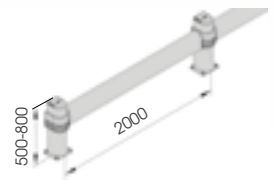

LINK SINGLE CORNER

External Corners available

Equipped with accessories

Packing Colour **unpacked on pallet**  
B M



NOW READY  
**NEW OPTIONS** FOR  
OUR **SAFETY BARRIERS**  
AND **RACK PROTECTORS**





AVAILABLE FOR:  
**LINK / SM / LM / FENCE**  
**HR 90 / PED 90 / PED 150**



# 08

## B FLEX

A new safety protection system with reinforced profile. It is a more flexible and shock-absorber solution. Designed to ensure high safety standards and to resist impacts from heavy loads. Available in many different versions.



Nuovo sistema di protezioni con profilo rinforzato, doppiamente flessibile e assorbente. Progettato e realizzato con un particolare design per garantire alti livelli di sicurezza e resistere all'impatto da carichi pesanti. Disponibile in diverse versioni.

Nouveau système de protection avec profil renforcé, doublement flexible et absorbant. Conçu et produit avec un design particulier pour assurer des niveaux élevés de sécurité et résister à l'impact des charges lourdes. Disponible en plusieurs versions.

Nuevo sistema de protección con perfil reforzado, más flexible y capaz de absorber los impactos. Diseñado para asegurar el entorno laboral y para resistir a los impactos de cargas pesadas. Disponible en diferentes versiones.

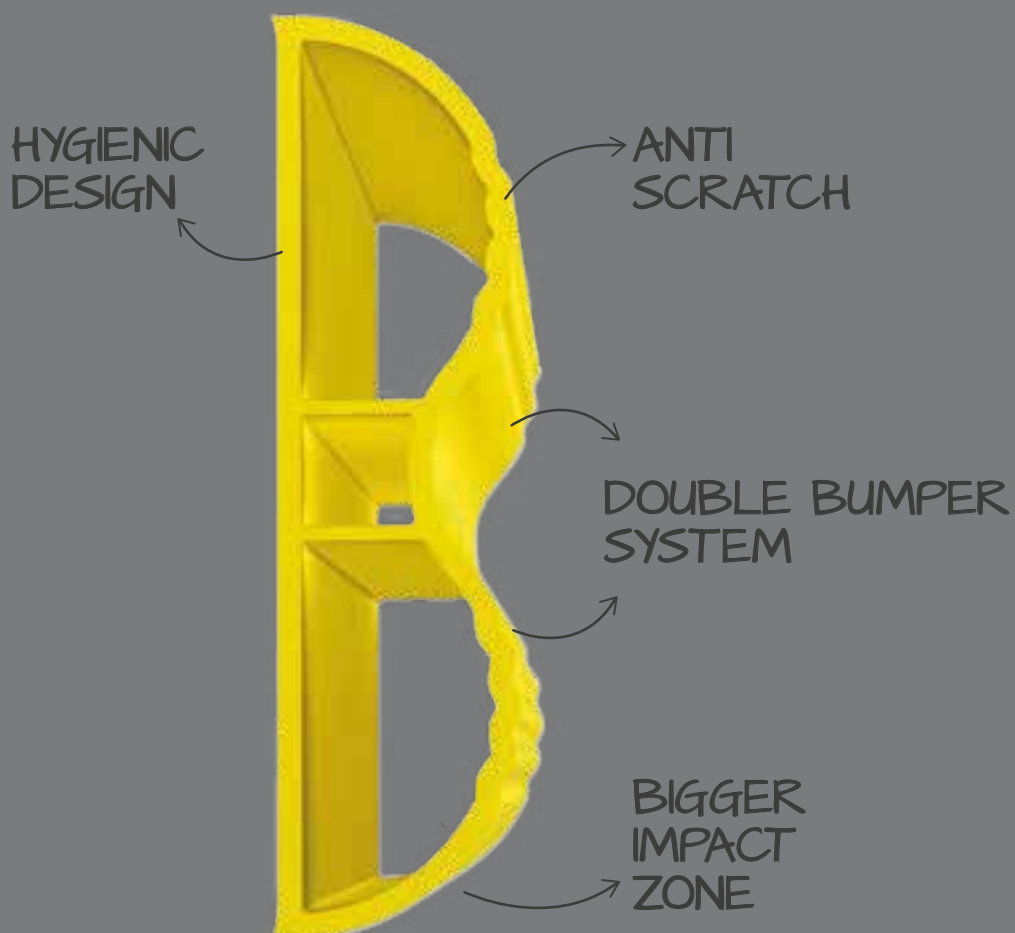





**BFLEX.FRONT/1 1100x450**  
**BFLEX.FRONT/1 2400x450**

Length **1.100 / 2.400 mm**  
 Packing **unpacked on pallet**  
 Colour **M**

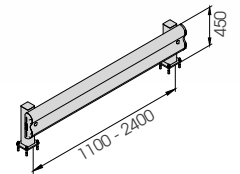

Equipped with accessories



**BFLEX.FRONT/1 2000x450**  
**MODULAR**

Packing **unpacked on pallet**  
 Colour **M**

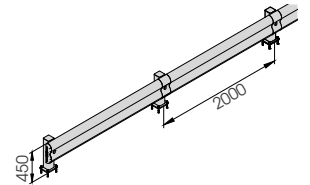

Equipped with accessories



# BFLEX.FRONT/2



**BFLEX.FRONT/2 1100x1100**  
**BFLEX.FRONT/2 2400x1100**

Length **1.100 / 2.400 mm**  
 Packing **unpacked on pallet**  
 Colour **M**

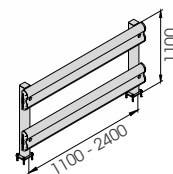

Equipped with accessories



**BFLEX.FRONT/2 2000x1100**  
**MODULAR**

Packing **unpacked on pallet**  
 Colour **M**

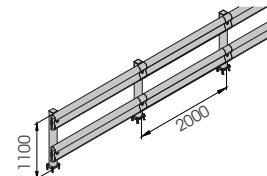

Equipped with accessories





**BFLEX.COM/1 1100x450**  
**BFLEX.COM/1 2400x450**

Length **1.100 / 2.400 mm**  
 Packing **unpacked on pallet**  
 Colour **M**

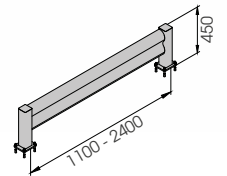

Equipped with accessories



**BFLEX.COM/1 2000x450**  
**MODULAR**

Packing **unpacked on pallet**  
 Colour **M**

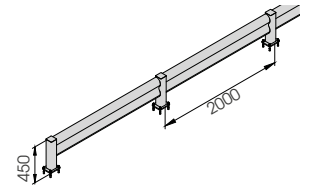

**Corners available**

Equipped with accessories





**B**FLEX.COM/2



**INCLUDED**

**S12 x 150 GALVANISED STEEL**



**BFLEX.COM/2 1100x1100**  
**BFLEX.COM/2 2400x1100**

Length **1.100 / 2.400 mm**  
Packing **unpacked on pallet**  
Colour **M**

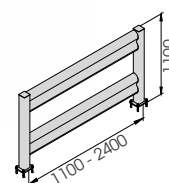

Equipped with accessories



**BFLEX.COM/2 2000x1100**  
**MODULAR**

Packing **unpacked on pallet**  
Colour **M**

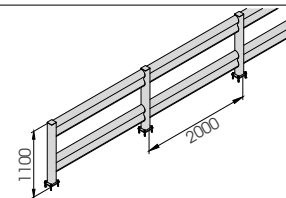

**Corners available**

Equipped with accessories



# 09

## COLUMN PROTECTION

A new bumper system specific for the protection of the columns resistant against trolleys movements and for different load types. Designed by following an innovative technical design that combines speed and simplicity in the steps of installation and cleaning. Available in different heights and fixing systems.

Sistema di profili specifico per la protezione delle colonne dai carrelli in movimento di varie portate. Progettato seguendo un innovativo disegno tecnico che coniuga rapidità e semplicità nella fasi di installazione e pulizia. Disponibile in diverse altezze e tipologie di fissaggio.

Nouveau système bumper, spécifique pour protéger les poutres contre les mouvements des chariots. Étudié avec un modern dessin qui regroupe la rapidité et la facilité pendant l'installation et le nettoyage. Disponible en différents hauteurs et différents fixations.

Sistema de perfiles específico para la protección de las columnas de los carros en movimiento de diferentes capacidades. Diseñado según un innovador diseño técnico que une velocidad y simplicidad en las fases de instalación y limpieza. Disponible en diferentes alturas y tipos de fijación.

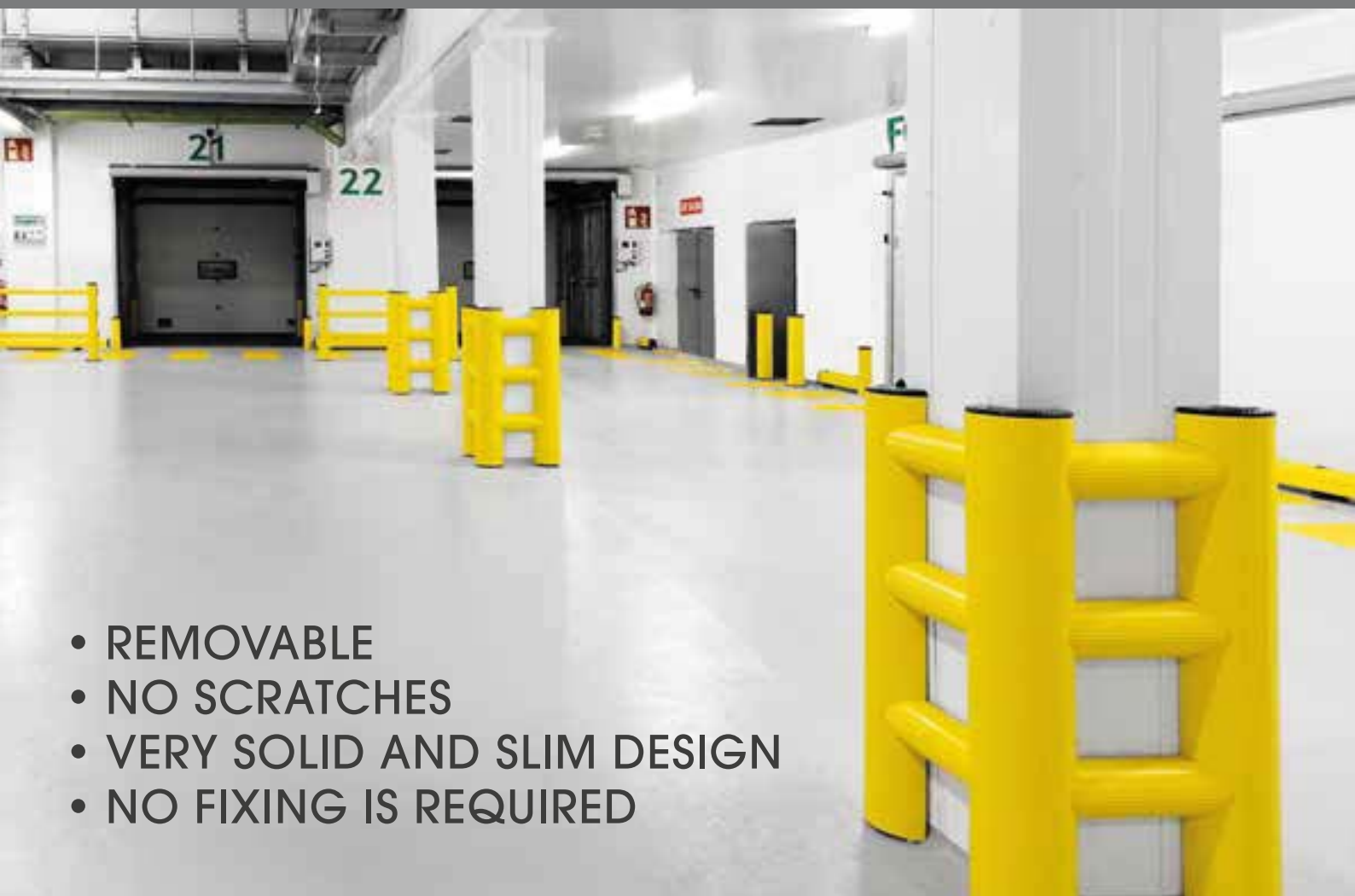

- REMOVABLE
- NO SCRATCHES
- VERY SOLID AND SLIM DESIGN
- NO FIXING IS REQUIRED

**NEW**

# MINI HUG TOWER

Column protection

DIFFERENT  
SIZED AND  
HEIGHT ON  
REQUEST

COMPACT



**NO HOLES  
ON THE FLOOR AND COLUMN!**

1100

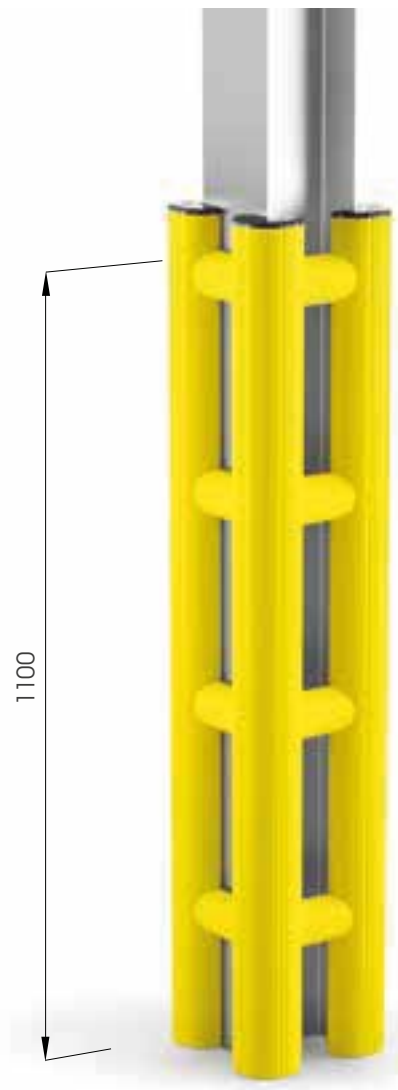

**MINI HUG TOWER**

Packing Colour **to be defined**  
**M**

Equipped with accessories

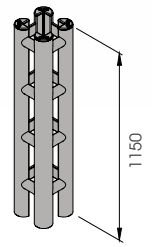



# HUG TOWER 3 SIDES



DIFFERENT SIZED ON REQUEST



WALL FIXING WITH S8FH GALVANISED STEEL

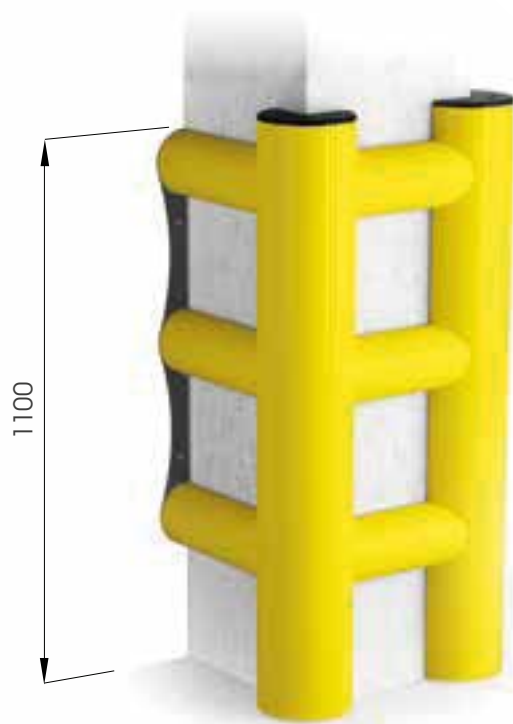

COMPACT



NO HOLES ON THE FLOOR AND COLUMN!



## HUG TOWER 3 SIDES

Also 2 SIDES available

Equipped with accessories

Packing Colour to be defined

M



# HUG TOWER



DIFFERENT  
SIZED AND  
HEIGHT ON  
REQUEST

COMPACT



**NO HOLES  
ON THE FLOOR AND COLUMN!**

CHOOSE THE  
HEIGHT YOU NEED!

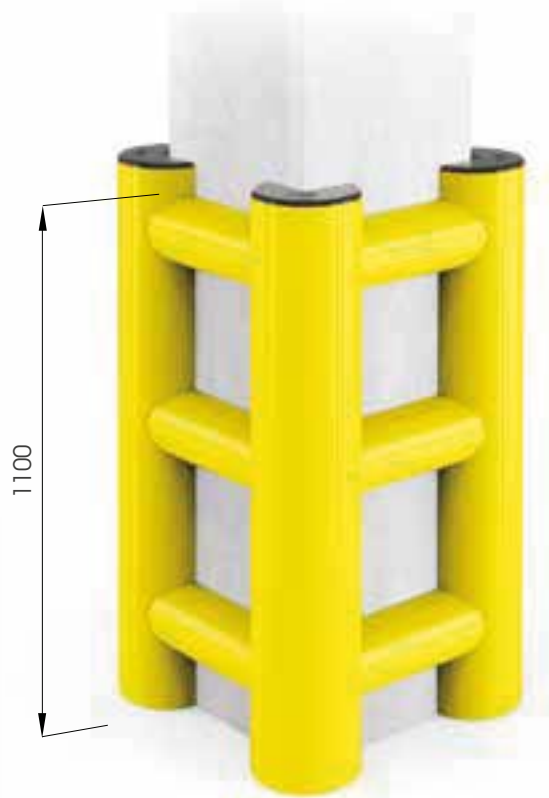
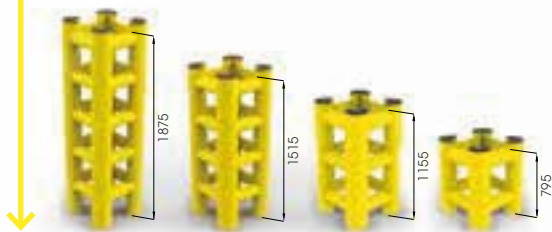

## HUG TOWER

Packing Colour **to be defined**  
M

Equipped with accessories

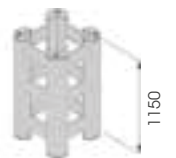

# TOWER PROTECTION



DIFFERENT  
SIZED AND  
HEIGHT ON  
REQUEST



M12  
GALVANISED STEEL

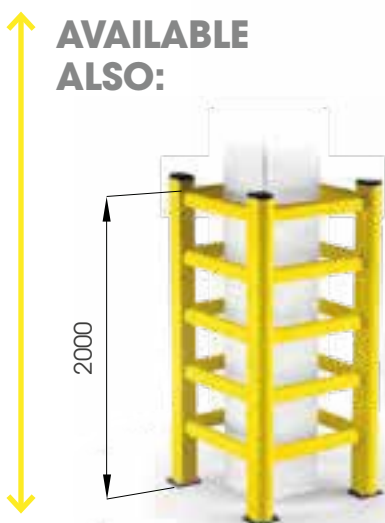

## TOWER

Also 2/3 SIDES  
available

Equipped with accessories

Packing  
Colour

to be defined

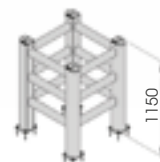



# TOWER LINK



DIFFERENT  
SIZED AND  
HEIGHT ON  
REQUEST



M12  
GALVANISED STEEL



## OPTIONS



TOWER LINK/1



TOWER LINK/2



TOWER LINK/3



TOWER LINK/1  
TOWER LINK/2  
TOWER LINK/3

Equipped with accessories

Packing Colour **to be defined**

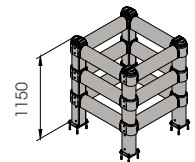

Column protection

# COLUMN PROTECTION 90



DIFFERENT SIZES ON REQUEST



M16  
STAINLESS STEEL



COPRO 90

Also 2/3 SIDES available

Equipped with accessories

Packing Colour **unpacked on pallet**

B M

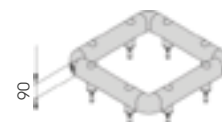

# COLUMN PROTECTION 150



SF20  
STAINLESS STEEL



**COPRO 150**

Also 2/3 SIDES  
available

Equipped with accessories

Packing Colour **unpacked on pallet**

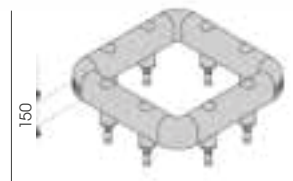



# 10

## DOOR FRAME PROTECTION

Protection system has been designed to prevent forklifts collisions with overhead infrastructure and gates and doors jambs. It is created to keep under control the passage of forklifts that exceed height limits, attracting the attention of drivers and inviting them to a more careful guide. Useful to protect gates, loading docks or overhead assets. Available in different lengths.

Sistema di protezione ideato per prevenire le collisioni dei carrelli elevatori in movimento con le infrastrutture sopraelevate e gli stipiti di porte e portoni. Limita il passaggio di carrelli che superano i limiti di altezza, attirando l'attenzione dei carrellisti e invitandoli ad una guida più accorta. L'installazione è consigliata in prossimità di portoni, baie di carico o di attrezzature sospese. Disponibile in diverse lunghezze.

Systèmes de protection conçus pour prévenir les collisions des chariots élévateurs en mouvement avec les infrastructures en hauteur et les montants des portes. Utiles pour empêcher le passage des chariots élévateurs qui dépassent les limites d'hauteur, pour attirer l'attention des conducteurs et de les habituer à faire plus attention à la conduite des chariots. C'est installé en proximité des bords des portes, quais de chargement et infrastructures suspendues. Disponible en plusieurs longueurs.

Sistema de protección diseñado para evitar la colisión de carretillas elevadoras en movimiento con infraestructuras, instalaciones elevadas y marcos de puertas industriales. Diseñada para limitar el paso de las carretillas que superan los límites de altura, llamando la atención de los conductores de montacargas e invitándoles a conducir con más cuidado. Se recomienda su instalación cerca de puertas industriales, muelles de carga o equipos suspendidos. Disponible en varias longitudes.



# WARNING BAR



## WBAR

Length 2000 / 3000 mm  
Packing to be defined  
Colour M

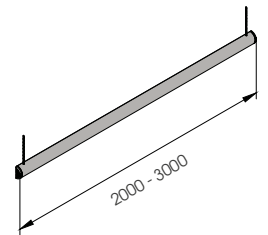

Equipped with accessories



# WARNING BAR / INFORMATION SIGN



**WBIS**

Length 2000 / 3000 mm  
Packing to be defined  
Colour **M**

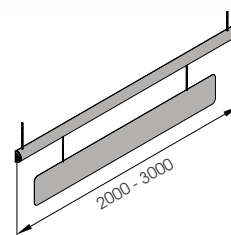

Equipped with accessories





# WARNING BAR / LIGHT & SOUND



102dB



UP TO  
70.000  
IMPACTS!



WBLS

Length 2000 / 3000 mm  
Packing to be defined  
Colour M

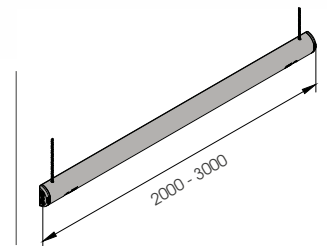

Equipped with accessories

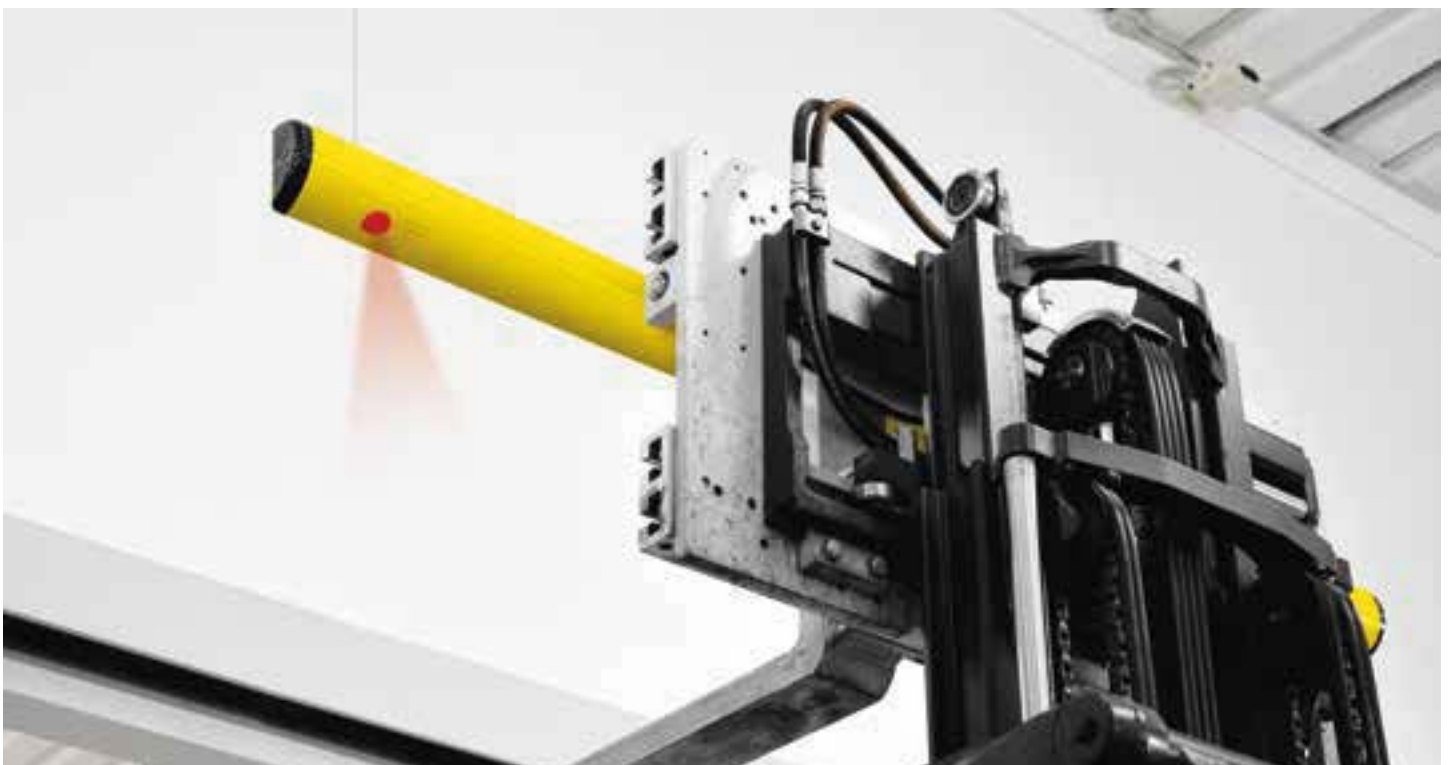

Door frame protection

# FULL FRAME SELF STANDING



DIFFERENT SIZES ON REQUEST

FAST AND EASY TO INSTALL

NEW BIGGER PLATES!

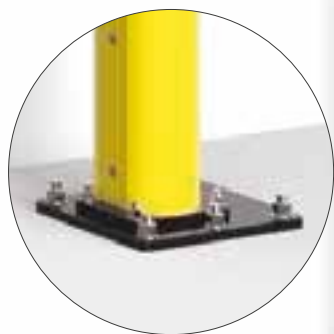

M16 GALVANISED STEEL



FFB SELF STANDING

Packing Colour **to be defined**

M

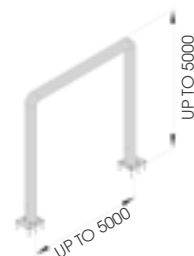

Equipped with accessories



# FULL FRAME WALL FIXING



DIFFERENT SIZES ON REQUEST

FAST AND EASY TO INSTALL

## WALL FIXING ACCESSORIES



M12 GALVANISED STEEL



FFB WALL FIXING

Packing Colour **to be defined**

M



Equipped with accessories





# 11

## LOADING BAY PROTECTION

Loading bays protections are shock-proof solutions which are set up near loading doors. They avoid possible slipping, falling and flipping of moving vehicles near open and unmanned loading bays.

Sistema di protezione antiurto installato in prossimità delle porte di carico. Permettono di evitare situazioni ad alto rischio di scivolamento, caduta e ribaltamento dei mezzi in movimento in presenza di baie di carico aperte e non presidiate.

Système de protection contre les chocs installé près des portes de chargement. Ils permettent d'éviter des situations en raison du risque élevé de glissement, de chute et de basculement des véhicules en mouvement en présence de quais de chargement ouverts et sans surveillance.

La protección de muelles de carga es un sistema anticolidión que está cerca de las puertas de carga. Evitan los riesgos de deslizamiento, caída y derrocamiento los vehículos en movimiento cuando están cerca de los muelles de carga abiertos y no vigilados.



# DOCK GATE



**M12  
GALVANISED STEEL**



- DOCK GATE L**      2400-2600
- DOCK GATE XL**    2605-2800
- DOCK GATE XXL**   2805-3000

Packing Colour **B** **M** to be defined

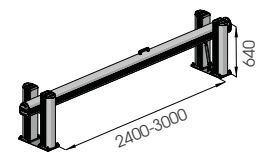

Equipped with accessories



# 12

## WHEEL STOP

Solutions designed for the safety of loading and unloading zones in warehouses and parking areas. Ideal for conveying, stopping or positioning the vehicle in the parking area, or near a cargo bay.

Soluzioni progettate per la sicurezza delle zone di carico e scarico dei magazzini e dei parcheggi. Ideali per convogliare, fermare o posizionare il mezzo nell'area di parcheggio o in prossimità di una baia di carico.

Solutions conçues pour la sécurité des zones de chargement et de déchargement des entrepôts et parkings. Idéal pour transporter, arrêter ou positionner le véhicule dans l'aire de stationnement ou à proximité d'un quai de chargement.

Soluciones diseñadas para asegurar las zonas de carga y descarga de almacenes y aparcamientos. Ideal para transportar, detener o posicionar el vehículo en la zona de aparcamiento o cerca de un muelle de carga.





# TRUCK LINE



DIFFERENT SIZES ON REQUEST



SF20 x 200 STAINLESS STEEL



TL	500	2000
	750	3000
	1000	4000
	1500	

Packing Colour to be defined

B M



Equipped with accessories



Wheel stop

# CAR STOP

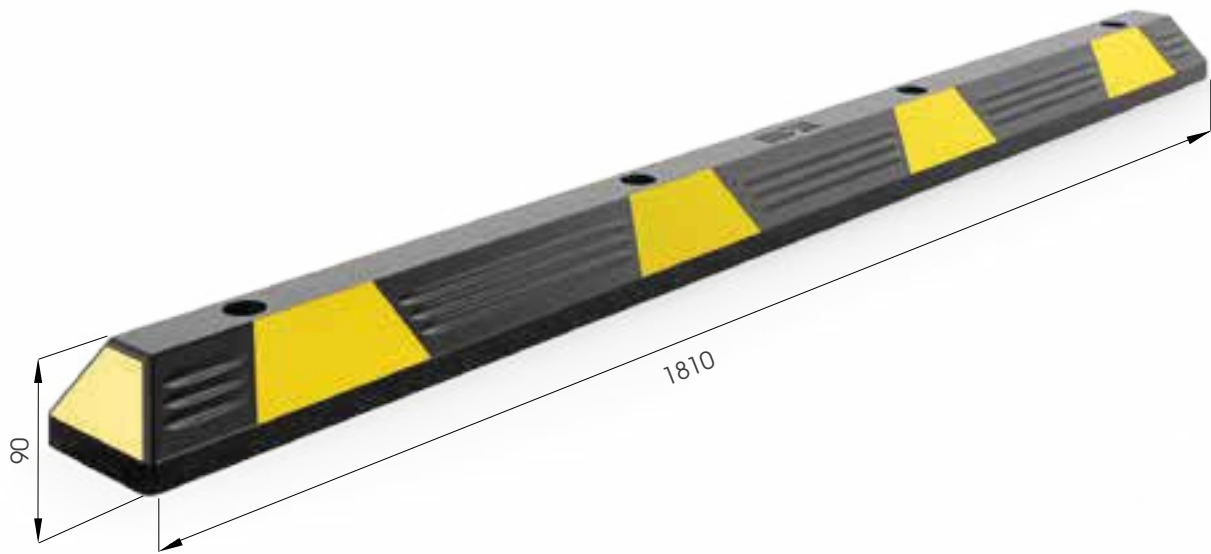

**CAR STOP**

Packing **to be defined**

Fixing on requests

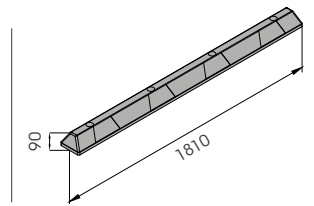

# TRUCK STOP



**TRUCK STOP**

Packing to be defined

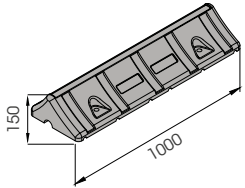

Fixing on requests





# 13

## CABLE COVER

Floor cable protection system in soft material. Space-saving, resistant and easy-to-install cable cover. Suitable for work areas with pedestrian passage.

Sistema di protezione morbido a pavimento per cavi. Passacavi poco ingombrante, resistente e facile da posare. Adatto ad aree di lavoro con passaggio di pedoni.

Système de protection de sol souple pour câbles. Guide-câble peu encombrant, résistant et facile à installer. Convient aux zones de travail avec passage piéton.

Sistema de protección blando de suelo para los cables. Pasacables que ahorra espacio, es duradero y fácil de instalar. Adecuado para zonas de trabajo con tráfico peatonal.

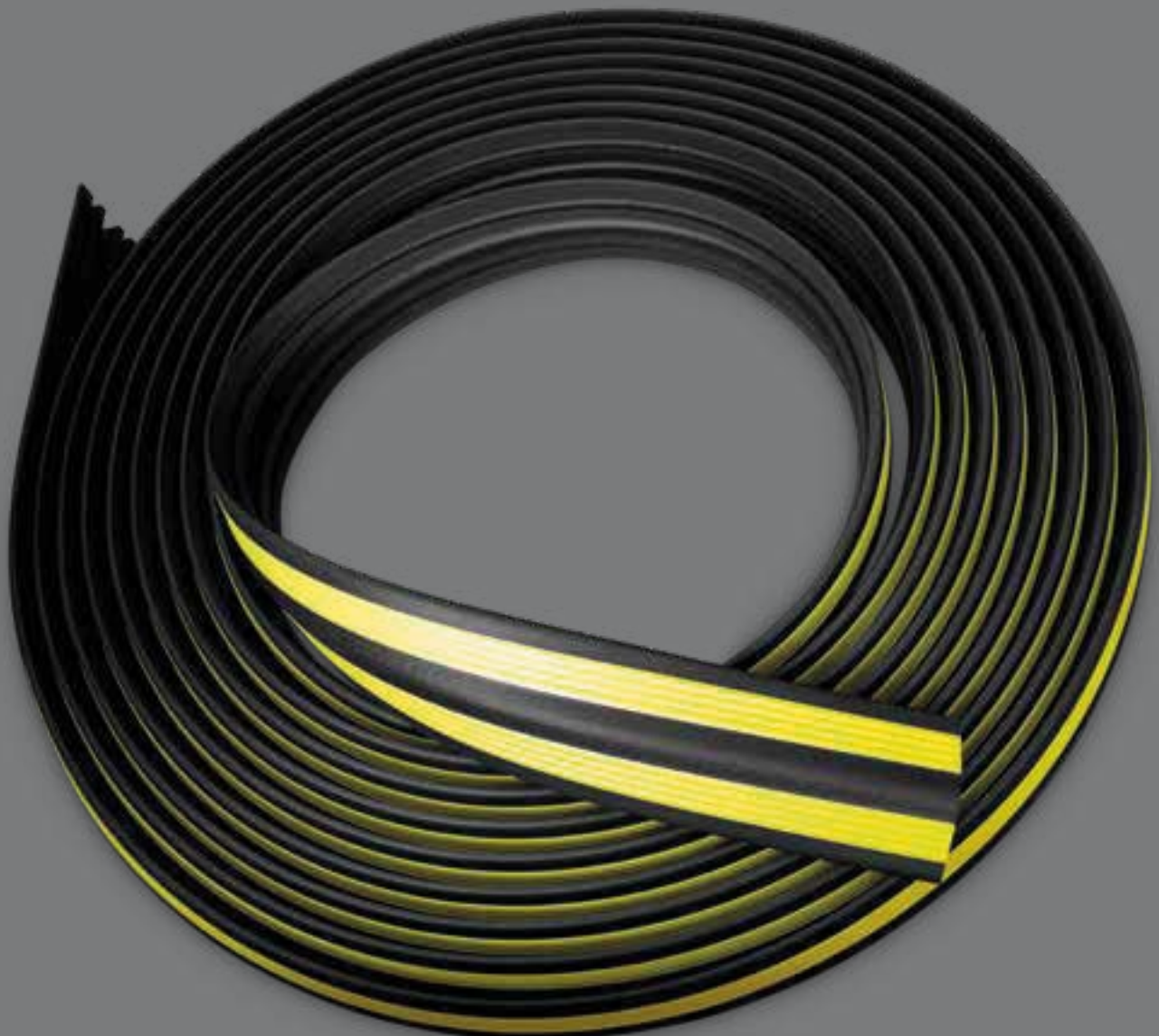

# CABLE COVER



**CAB CO 10 - 20 - 10**

Length 1.000 / 3.000 mm - 10.000 mm  
 Packing 8 pz / box - 1 pz / box

Recycled Material

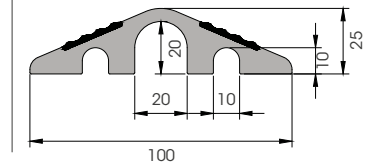

# 14

## CORNER PROTECTION

Designed to protect pillars and columns or external corners of walls and panels.

Realizzato per proteggere pilastri e colonne o angoli esterni di muri e pannelli.

Etudié pour protéger les poteaux et les colonnes ou les angles extérieurs de murs et de panneaux.

Realizado para proteger pilares y columnas o esquinas exteriores de paredes y paneles.







**CP 100**

Length **4.000 mm**  
 Packing **10 pz / box**  
 Colour **B M E F**

Length **2.000 mm**  
 Packing **10 pz / bag**  
 Colour **M**

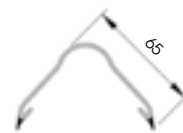

**CPF 100**

Length **4.000 mm**  
 Packing **10 pz / bag**

Length **2.000 mm**  
 Packing **10 pz / bag**



**CPT 100**

Packing **40 pz / box**  
 Colour **B E F**



**CP 200**

Length **4.000 mm**  
 Packing **2 pz / bag**  
 Colour **B M E**

Length **2.000 mm**  
 Packing **2 pz / bag**  
 Colour **M**



**CPF 200**

Length **2.000 / 4.000 mm**  
 Packing **2 pz / bag**



**CPT 200**

Packing **20 pz box**  
 Colour **B E**

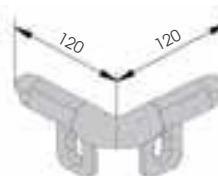

# 15

## KERB

A large size protection system, ideal for walls and panels. Easy to install and clean. Fully equipped with corner caps and buttons.



Sistema di protezione di grandi dimensioni,  
ideale per muri e pannelli. Facile da installare e pulire  
Completo di angolari e tappi.

Système de protection  
de grands dimensions, idéal  
pour les murs et les panneaux.  
Facile à installer et à nettoyer.  
Complété de bouchons  
d'angles et d'embouts.

Sistema de protección  
de grande dimensión,  
ideal para paredes  
y paneles. Fácil de instalar  
y limpiar. Completo de  
esquinas y tapas.

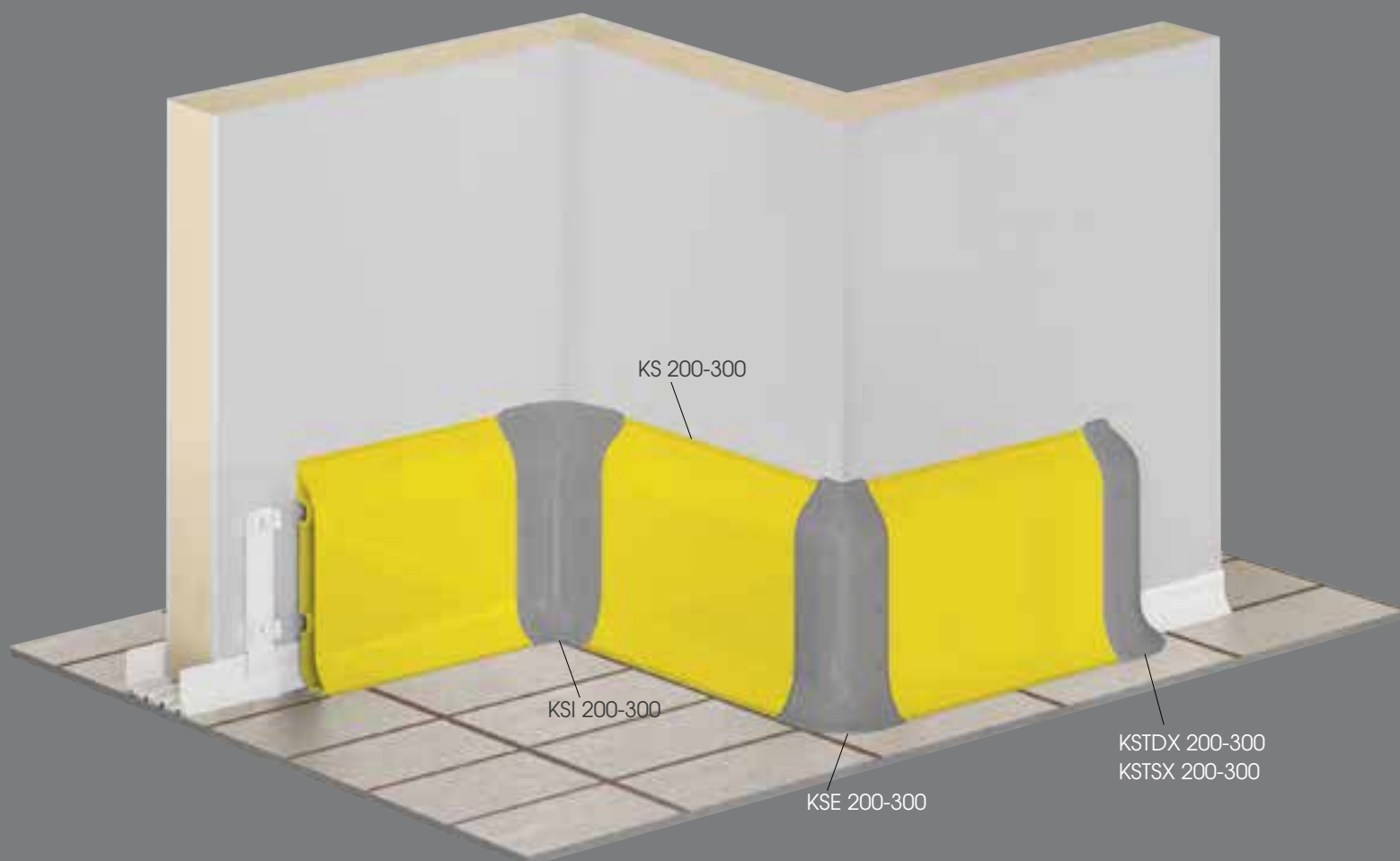



# Kerb



**KS 200**

Length **4.000 mm**  
 Packing **3 pz / box**  
 Colour **B M E**

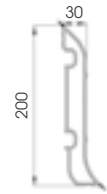

**KEPF 200**

To install with TB14

Packing **50 pz / box**  
 Colour **K**

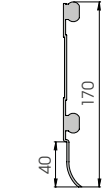

**KSJ 200**

To install with TB14 / TF14

Packing **20 pz / box**  
 Colour **B E**

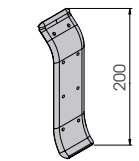

**KSI 200**

To install with TB14 / TF14

Packing **20 pz / box**  
 Colour **B E**

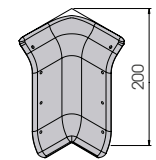

**KSE 200**

To install with TB14 / TF14

Packing **20 pz / box**  
 Colour **B E**

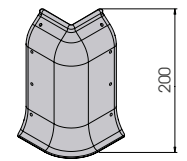

**KSTDX/SX 200**

To install with TB14 / TF14

Packing **20 pz / box**  
 Colour **B E**

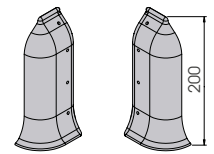

**KSJ 200 LT**



Packing **to be defined**  
 Colour **K**



**KS 300**

Length **4.000 mm**  
 Packing **1 pz**  
 Colour **M E**

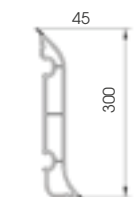

**KEPF 300**

To install with TB20

Packing **40 pz / box**

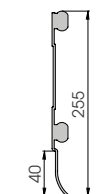



**KSJ 300**  
To install with TB20 / TF20

Packing 10 pz / box  
Colour B E

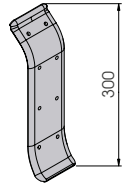

**KSI 300**  
To install with TB20 / TF20

Packing 10 pz / box  
Colour B E

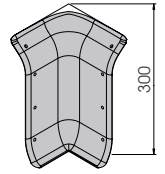

**KSE 300**  
To install with TB20 / TF20

Packing 10 pz / box  
Colour B E

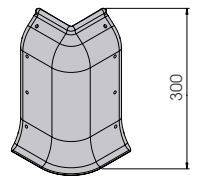

**KSTD/SX 300**  
To install with TB20 / TF20

Packing 10 pz / box  
Colour B E

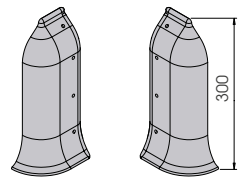

# 16

## WALL PROTECTION

New bumper without guides. Thanks to its big size and resistance it is ideal for protection of industrial spaces. Fixed caps with hidden screws covered by specific buttons.

Nuovo profilo antiurto senza guida. La sua ampiezza e resistenza lo rende ideale per la protezione di ambienti industriali. Terminali fissati con viti nascoste da appositi bottoni.

Nouveau profilé anti-choc sans besoin d'une base à fixer. Sa mesure large et sa résistance en font le profilé parfait pour la protection des espaces industriels. Embouts fixés avec des vis cachées grâce à des bouchons spécifiques.

Nuevo perfil antigolpe sin guía. Su amplitud y resistencia lo hacen ideal para la protección de entornos industriales. Terminales fijados con tornillos ocultos por botones especiales.







## WP 100

Length **4.000 mm**  
Packing **8 pz / box**  
Colour **B E F**

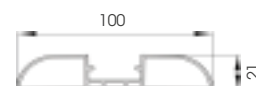

## WP 150

Length **4.000 mm**  
Packing **4 pz / box**  
Colour **B M E**

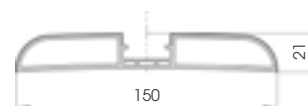

## WPC

To install with WP 100 / WP 150

Length **4.000 mm**  
Packing **16 pz / box**  
Colour **A B M D E F G H**

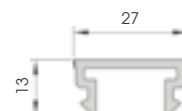

## WPT 100

To install with TM5

Packing **50 pz / box**  
Colour **B E F**

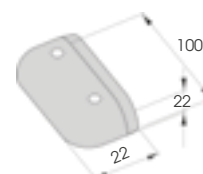

## WPA 100

To install with TS9

Packing **20 pz / box**  
Colour **B E**

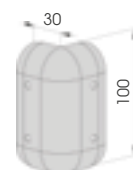

## WPT 150

To install with TM5

Packing **50 pz / box**  
Colour **B E**

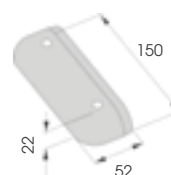

## WPA 150

To install with TS9

Packing **20 pz / box**  
Colour **B E**

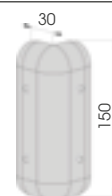

# Wall Protection

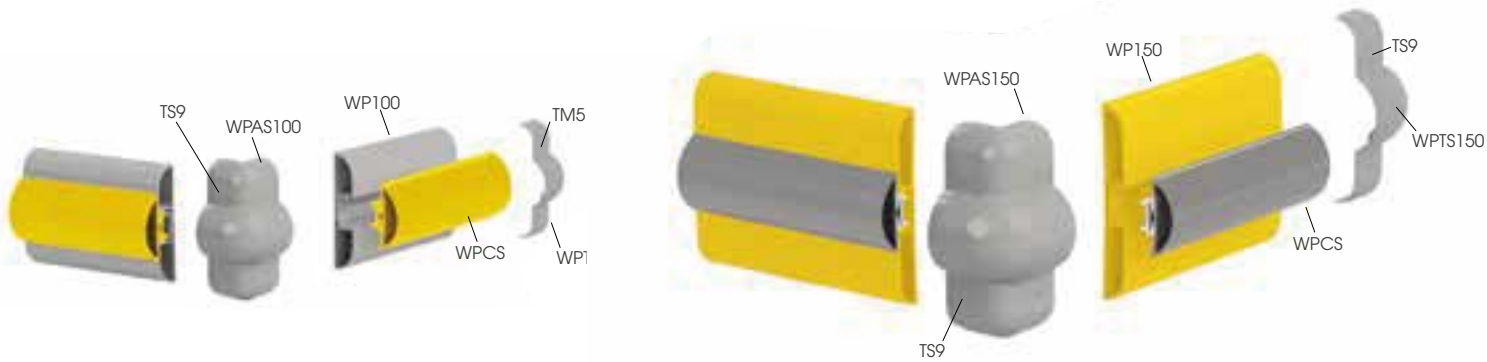

## WP 100

Length **4.000 mm**  
 Packing **8 pz / box**  
 Colour **B E F**

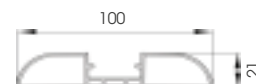

## WP 150

Length **4.000 mm**  
 Packing **4 pz / box**  
 Colour **B M E**

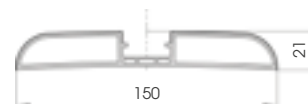

## WPCS

To install with WP 100 / WP 150



Length **4.000 mm**  
 Packing **8 pz / box**  
 Colour **A B M D E F G H I**

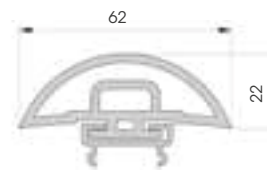

## WPTS 100

To install with TS9

Packing **20 pz / box**  
 Colour **B E**

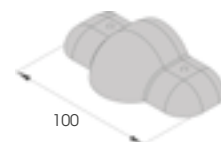

## WPAS 100

To install with TS9

Packing **20 pz / box**  
 Colour **B E**

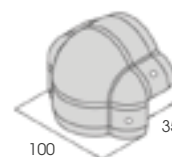

## WPTS 150

To install with TS9

Packing **20 pz / box**  
 Colour **B E**

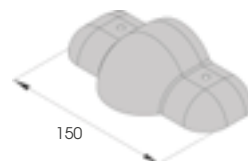

## WPAS 150

To install with TS9

Packing **20 pz / box**  
 Colour **B E**

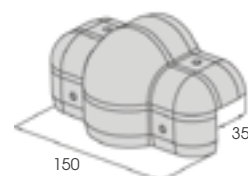

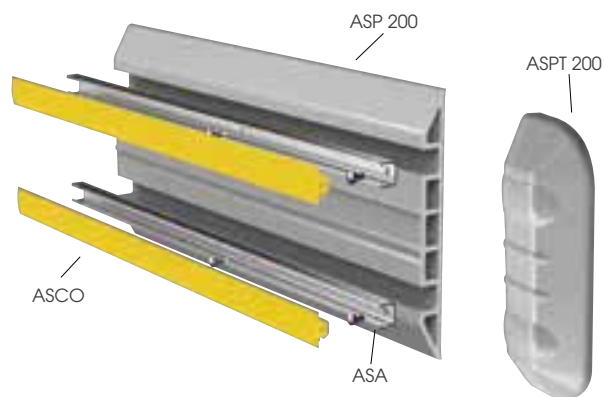

**ASP 200**



Length **4.000 mm**  
 Packing **2 pz / box**  
 Colour **B M**



**ASPT 200**



Packing **10 pz / box**  
 Colour **B D**

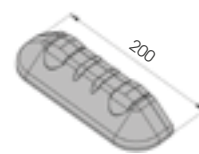

**ASA**

Material **aluminium**  
 Length **4.000 mm**  
 Packing **8 pz / bundle**



**ASCO**



Packing **2 pz / box**  
 L = **32.000 mm**  
 Colour **A B M D E**





# Wall Protection



**WALL HUG** 1000  
2000  
3000  
4000

Length 1000/2000/3000/4000  
Packing unpacked  
Colour M

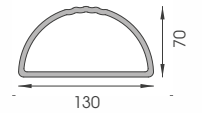

**WALL BFLEX** 1000  
2000  
3000  
4000

Length 1000/2000/3000/4000  
Packing unpacked  
Colour M

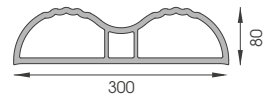

**WALL BFLEX MODULAR**

Packing unpacked  
Colour M

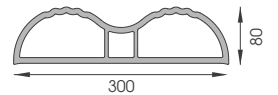



## LOFT BARRIER

WORLD'S FIRST FIXED PROTECTION SYSTEM FOR SUSPENDED AREAS



## FLEXI LINE

CORNER BUMPER GUARDS



## FENCE LINK

THE ADAPTABLE STRONGEST SOLUTION FOR RACK-ENDS

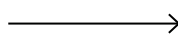

Now available  
**CUSTOMISED RACK PROTECTOR,**  
new version of rack protector  
processed upon request!

CUSTOMISED **RACK PROTECTOR**

## Fixing accessories



### M12 - M16

**HILTI**

Hole required  $\varnothing$  12-16  
Galvanized steel.



### S12 - S12X150 - S16

**HILTI**

Hole required  $\varnothing$  10-10-14  
Galvanized steel.



### B12 - B16 - B20

**HILTI**

Hole required  $\varnothing$  22-28-32  
Galvanized steel.



### S8FH - S12FH

**HILTI**

Hole required  $\varnothing$  6-10  
Galvanized steel.  
Countersunk.



### SF12 - SF16 - SF20 INOX

Hole required  $\varnothing$  14-18-24  
Stainless steel.



### M12 - M16 INOX

Hole required  $\varnothing$  12-16  
Stainless steel.



### KIT ROD 70-120

**HILTI**

Hole required  $\varnothing$  38-56  
Galvanized steel.



### KIT ROD 70-120 INOX

**HILTI**

Hole required  $\varnothing$  38-56  
Galvanized steel.



### AA12 - AA16

Hole required  $\varnothing$  22-22  
Galvanized steel.  
For asphalt.



### ASPHALT CHEMICAL

**CHEMICAL ANCHOR**

385 ML



### FR

**HILTI CHEMICAL ANCHOR**

300 ML



### WIT NORDIC

**CHEMICAL ANCHOR**

420 ML

(Installation in working cold rooms  
with negative temperatures)



MPM srl reserves the right, at any time, to introduce the necessary changes and improvements to its products. Any small imperfection in the products and in the materials used are due to the processing method. Any reproduction of this brochure, even in part, is forbidden.



**TM5**  
Hole required  $\varnothing$  8.5  
Neutral polyethylene. 100/500 Pcs. / bag.



**TS9**  
Hole required  $\varnothing$  5  
White or grey nylon. 1000 Pcs. / bag.



**TB14 - TB20**  
Hole required  $\varnothing$  4-5  
Steel / aluminium (white for  $\varnothing$  4)  
500 Pcs. / box.



**TF14 - TF20**  
Hole required  $\varnothing$  5-6.5  
Aluminium. 500 Pcs. / box.



**FIX P90**  
Galvanized steel and painted.



**COVER 90 RE**  
Galvanized steel and painted.



**FIX P90 INOX**  
Stainless steel.



**FIX P150**  
Galvanized steel and painted.



**COVER 150 RE**  
Galvanized steel and painted.



**FIX P150 INOX**  
Stainless steel.



**FIX P150 FH**  
Galvanized steel and painted.  
Countersunk.



**FULL FRAME BASE**  
Galvanized steel and painted.



**SHOCK ABSORBER PAD**  
Soft material, optional for FIXP150.  
(To be installed with S12x150)

## Colours



RED  
RAL 3002



GREY  
RAL 7040



BLACK  
RAL 9005



WHITE  
RAL 9010



WHITE  
RAL 9002



BLUE  
RAL 5005



GREEN  
RAL 6029



SILVER  
RAL 9006



LIGHT GREY  
RAL 7035



DARK GREY  
RAL 7024



LIGHT YELLOW  
RAL 1018



ORANGE

MPM srl reserves the right, at any time, to introduce the necessary changes and improvements to its products.  
Any small imperfection in the products and in the materials used are due to the processing method.  
Any reproduction of this brochure, even in part, is forbidden.





THE WORLD'S TOP **LOGISTICS**  
PROFESSIONALS CHOOSE OUR  
**QUALITY MADE IN ITALY**





## SOME OF OUR REFERENCES





# OUR INSTALLATION







# OUR INSTALLATION



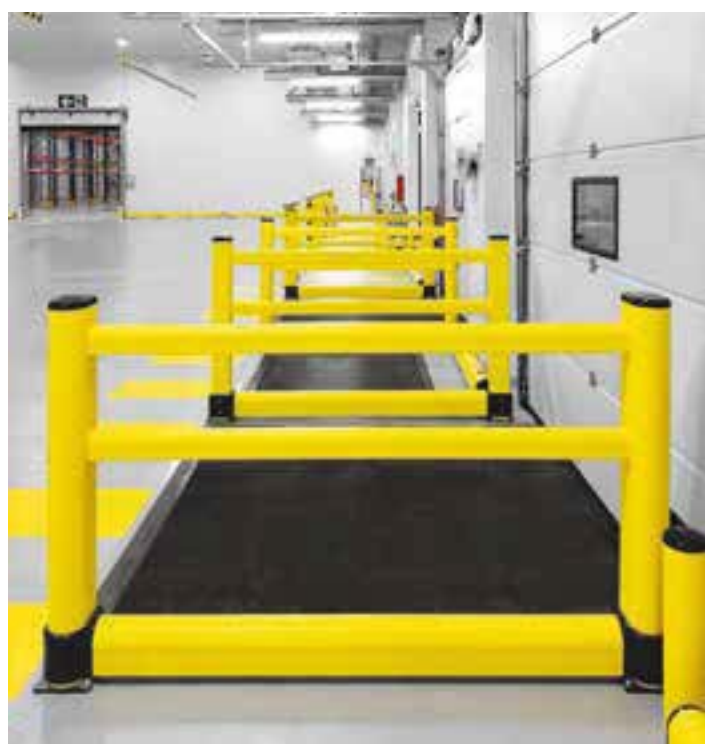



# OUR INSTALLATION

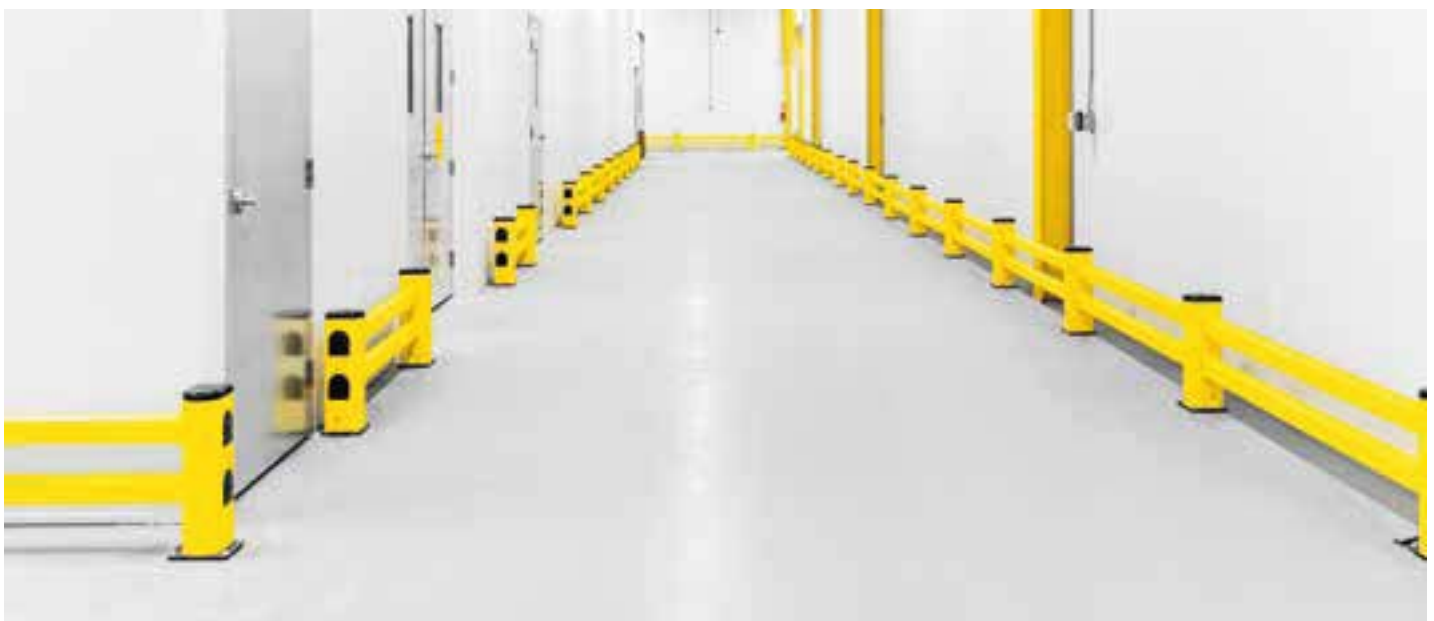



**MPM states that:**

The safety coefficient and consequent use of the products requires the compliance with the appropriate assembling and installation instructions as defined in the technical catalogue on the corporate website **[www.mpmprotections.com](http://www.mpmprotections.com)**. Therefore, before buying and installing MPM solutions please consult the technical data sheet of each product in the technical catalogue available on **[www.mpmprotections.com](http://www.mpmprotections.com)**

Impact resistances indicated in the brochure, or in other documents, refer to laboratory tests and cannot take into account consequences determined by installation methods or peculiarities of the place where the products are installed (in an operational environment vehicle type, speed and mass, routes, angles of impact, ground and anchorage are variable and uncontrolled conditions that no test can replicate); the data refers to an intact product which length is indicated on the test report and it can be affected by alterations from incorrect maintenance, wear and tear, as well as the methods and characteristics of installation (with specific reference to floor-mounted products); the weight, dimensions, colours and characteristics of the material refer to the sample and the conformity with the latter of the product supplied will be subject to normal production tolerance. The product may be affected by environmental installation conditions.

The standard operating temperature of MPM flexible protections is generally from +5 °C to +60 °C. For installations in low temperature environments up to -30 °C an alternative material should be required. The fastness of the colour and its brightness depend on wear and tear and weather conditions that can affect its intensity over time. For outdoor applications exposed to direct sunlight it is possible to choose the grey colour.

Images in the brochure are for advertising purposes only and do not in any way represent how the products should be used.

Full version of MPM products warranty available on corporate website **[www.mpmprotections.com](http://www.mpmprotections.com)**



**Servicio integral**

de seguridad avanzada

PARA FLUJOS DE TRABAJO  
INDUSTRIALES

---

**Contacto**

---

+34 620 526 473

info@safeway360.com

Carrer Aumet, 66

17460 Celrà, Girona

**BARRERAS  
FLEXIBLES**



**Safeway360**

**360**