

TECHNICAL DATA SHEETS

PLASTIC PROTECTIONS AND SAFETY BARRIERS

NEW
COLD LINE

MADE IN ITALY

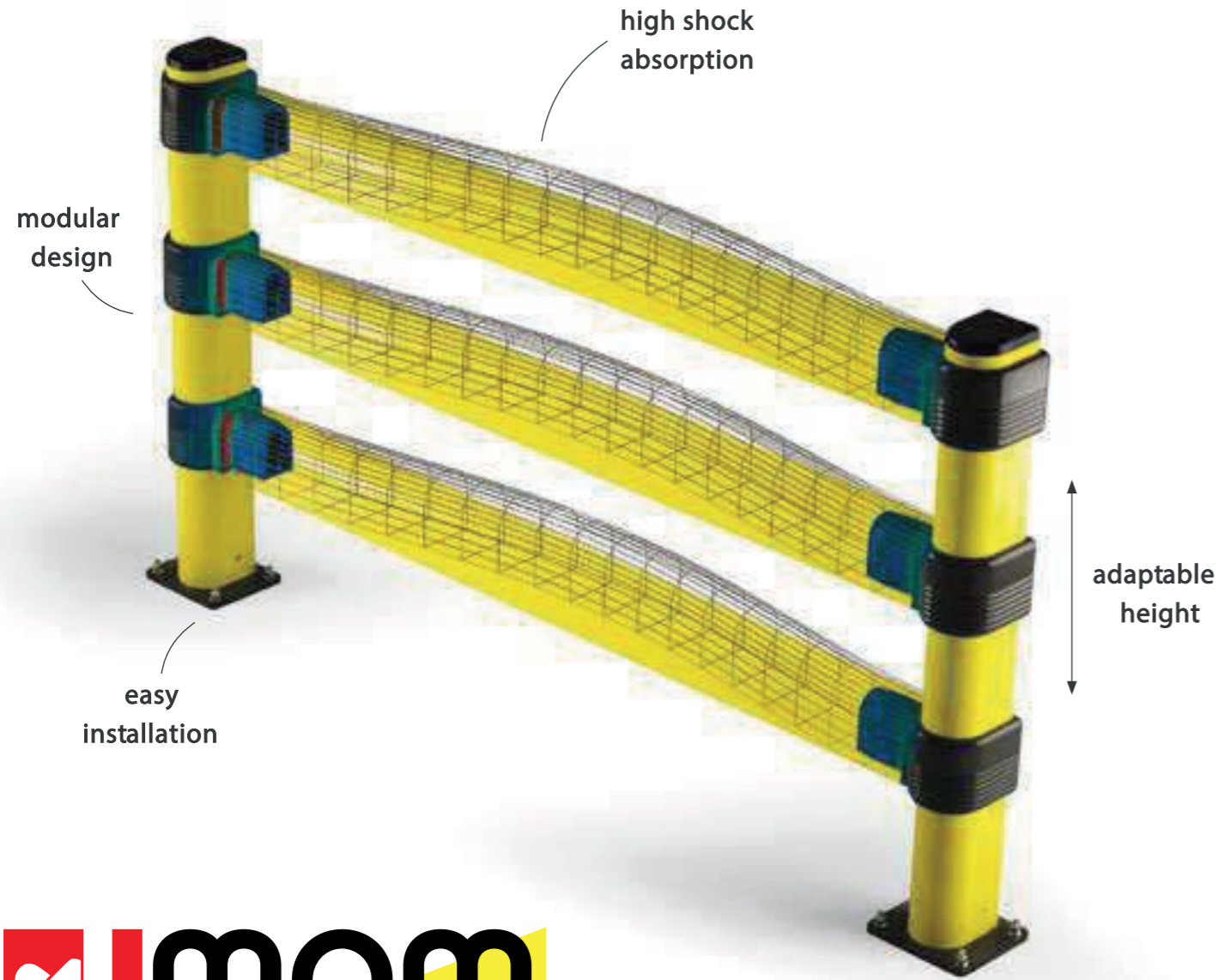



SAFETY ENGINEERING
FOR A SAFE WORK

Safeway360

SEGURIDAD GLOBAL

Exterior & Interior

Protección de personas



Protección de activos y bienes

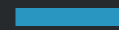

Señalización temporal y definitiva



Delimitaciones de zonas de trabajo



Diseño y soluciones a medida



ESTUDIO Y PROYECTO



PRODUCTO E INSTALACIÓN



POSTVENTA Y MANTENIMIENTO

TRUCK LINE

ISTRUZIONI DI INSTALLAZIONE
ASSEMBLY INSTRUCTIONS

WARNING
The distance of installation depends
on speed and weight of vehicle

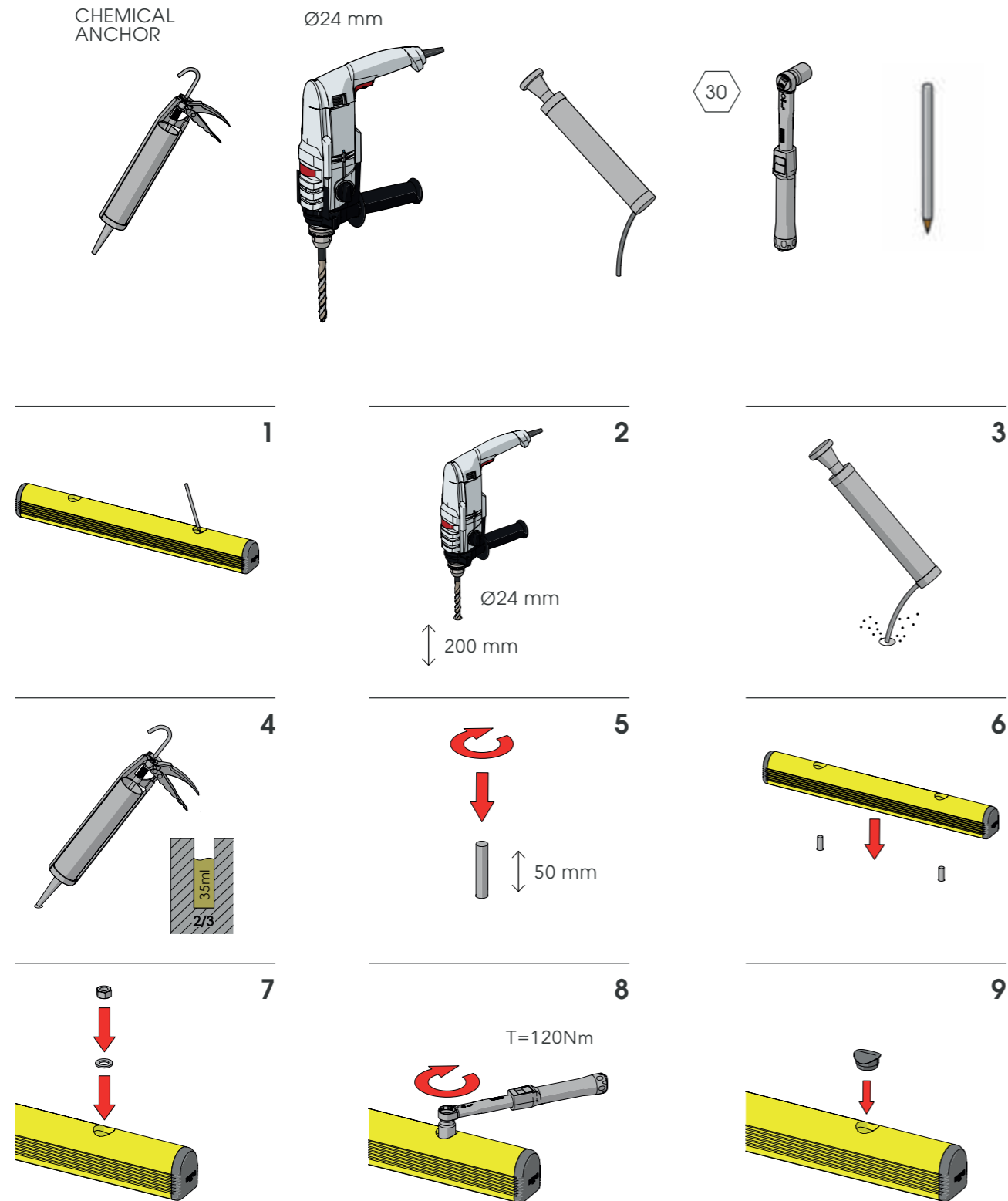

GR 90

BARRIERA SINGOLA
SINGLE-RAIL BARRIER

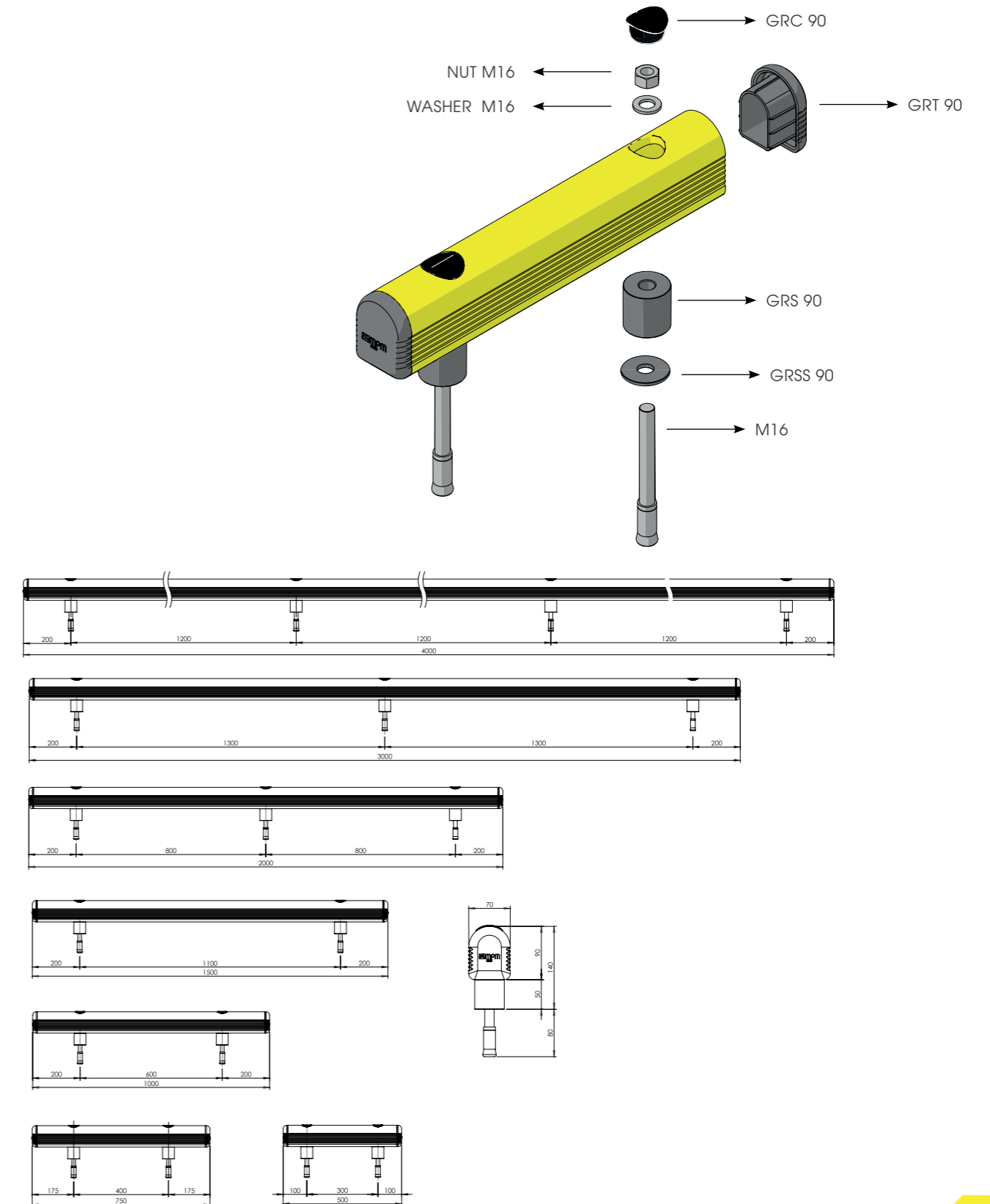

GR 90

ISTRUZIONI DI INSTALLAZIONE
ASSEMBLY INSTRUCTIONS

WITH EXPANSION SCREW

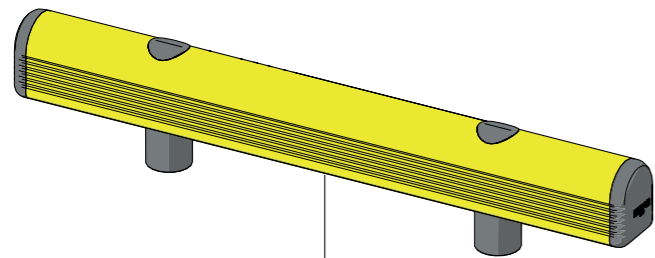

WARNING
The distance of installation depends on speed and weight of vehicle

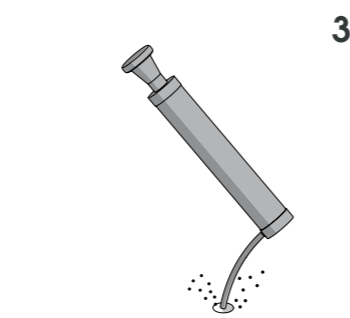
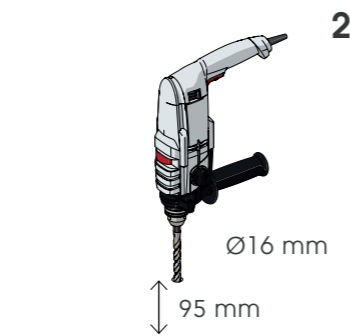
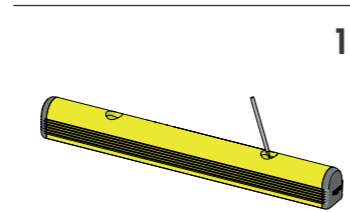
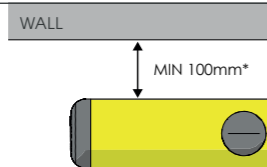

GR 90

ISTRUZIONI DI INSTALLAZIONE
ASSEMBLY INSTRUCTIONS

WITH EXPANSION SCREW

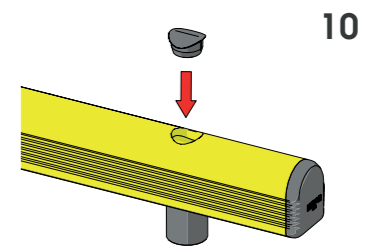
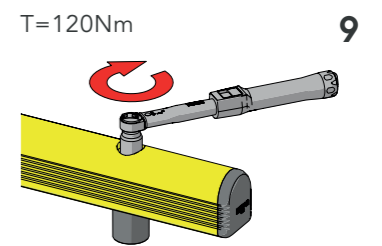
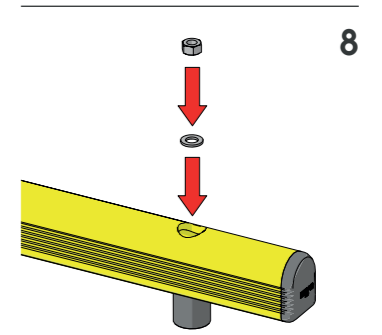
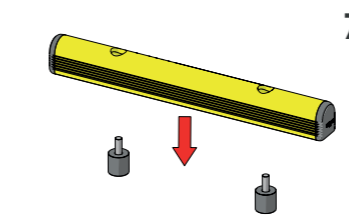
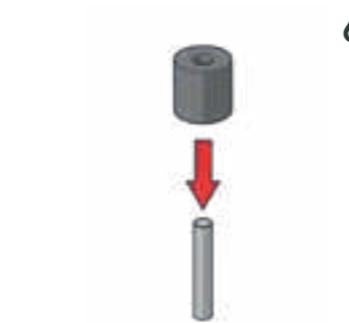
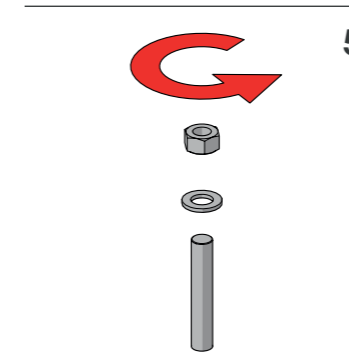

GR 90

ISTRUZIONI DI INSTALLAZIONE
ASSEMBLY INSTRUCTIONS



WITH RESIN

CHEMICAL ANCHOR

Ø18 mm

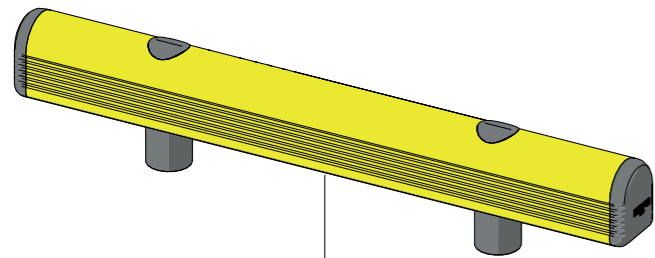

WARNING
The distance of installation depends on speed and weight of vehicle

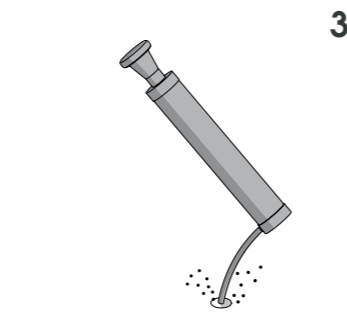
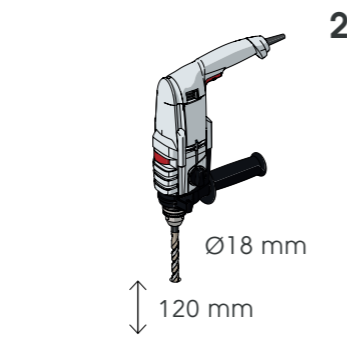
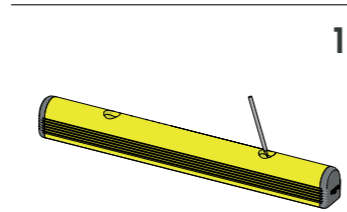
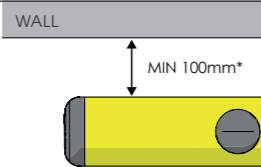

GR 90

ISTRUZIONI DI INSTALLAZIONE
ASSEMBLY INSTRUCTIONS



WITH RESIN

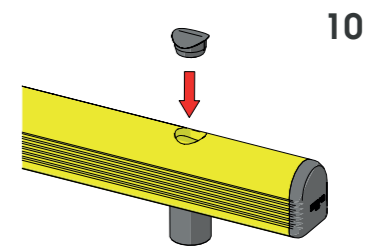
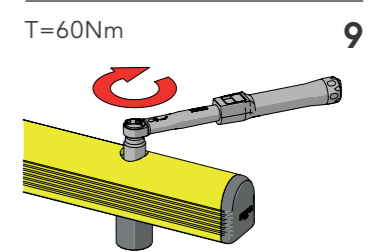
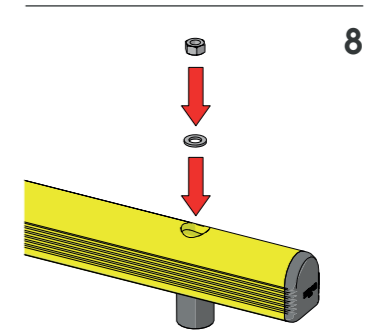
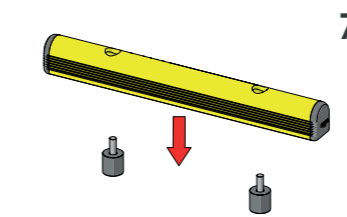
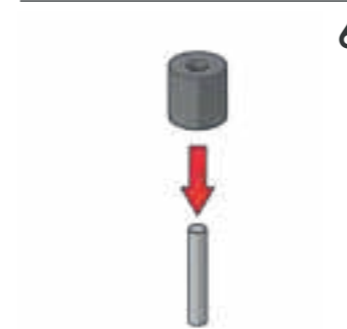
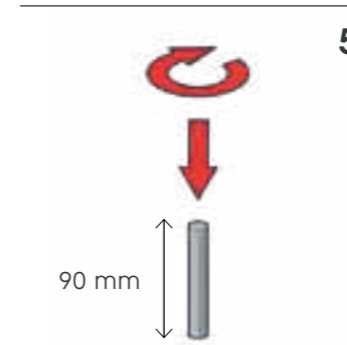

GR 150

BARRIERA SINGOLA
SINGLE-RAIL BARRIER

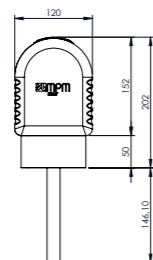
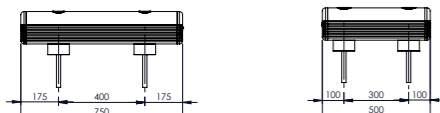
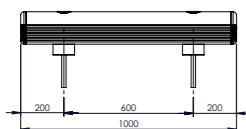
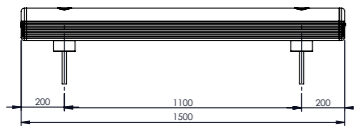
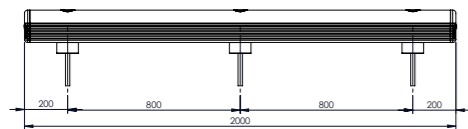
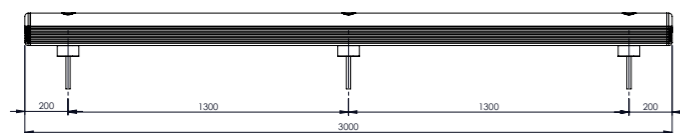
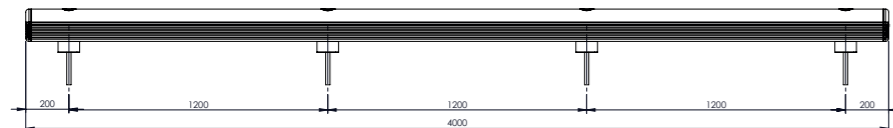
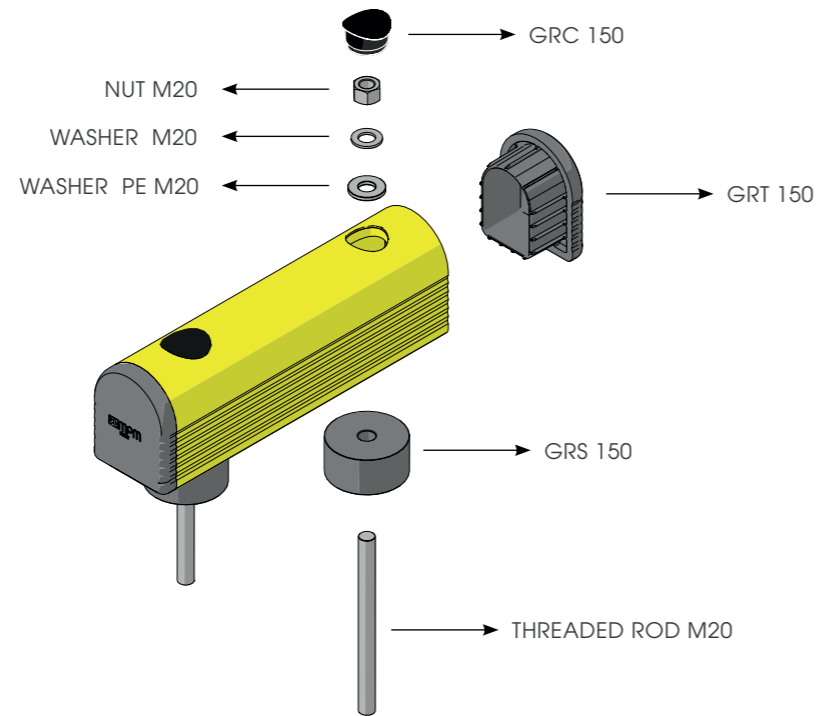

GR 150

ISTRUZIONI DI INSTALLAZIONE
ASSEMBLY INSTRUCTIONS

ONLY WITH RESIN

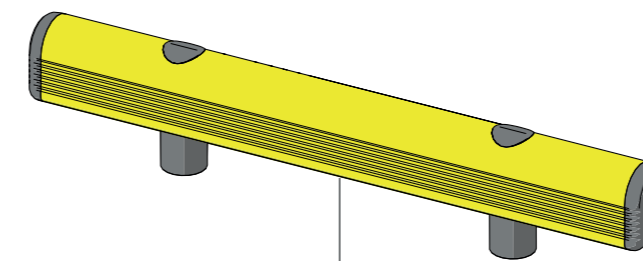

WARNING
The distance of installation depends on speed and weight of vehicle

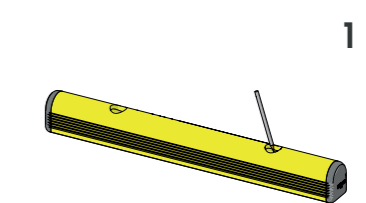
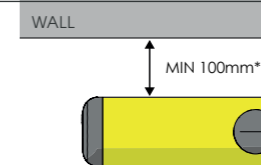

1

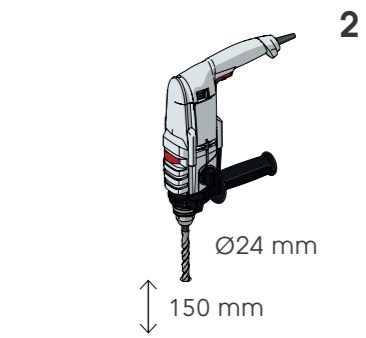

2



3

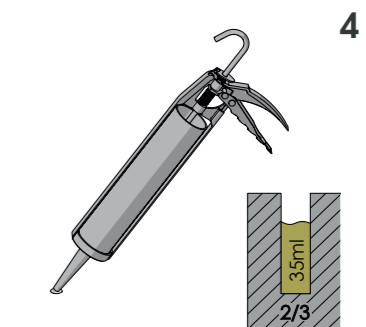

4

GR 150

ISTRUZIONI DI INSTALLAZIONE
ASSEMBLY INSTRUCTIONS

ONLY WITH RESIN

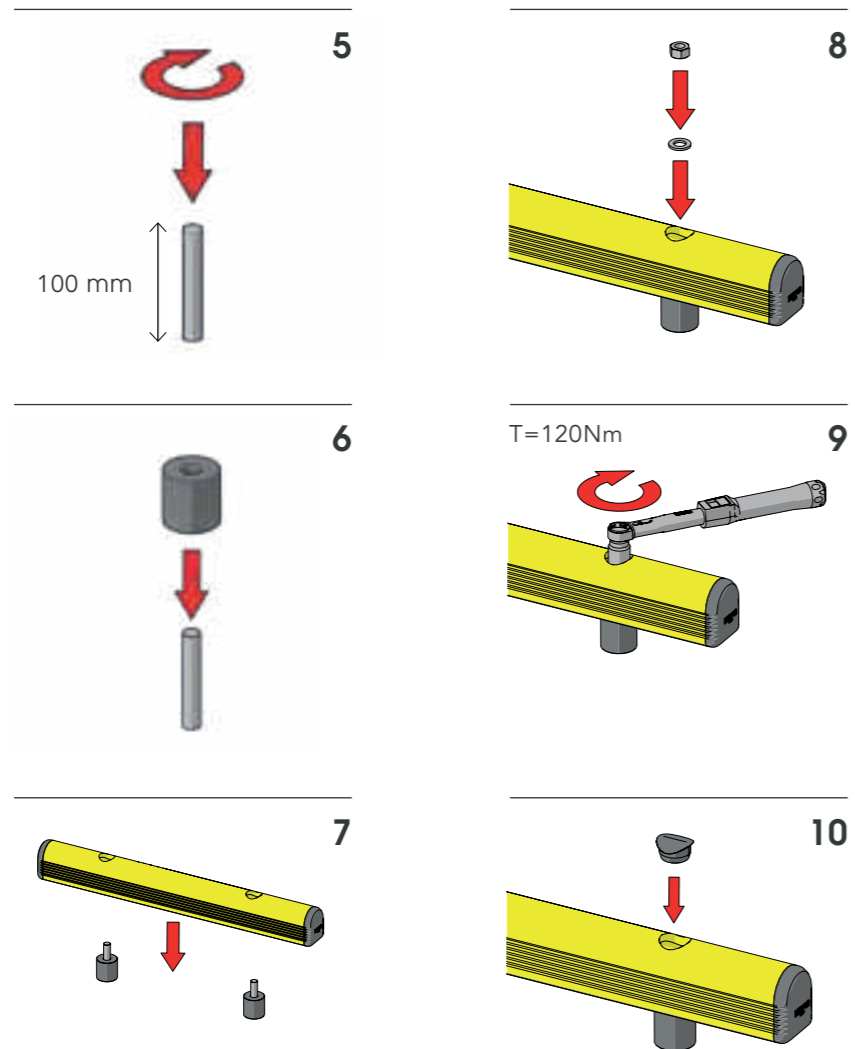

GRIN 90

GUARD RAIL CONTINUO
CONTINUOUS GUARD RAIL

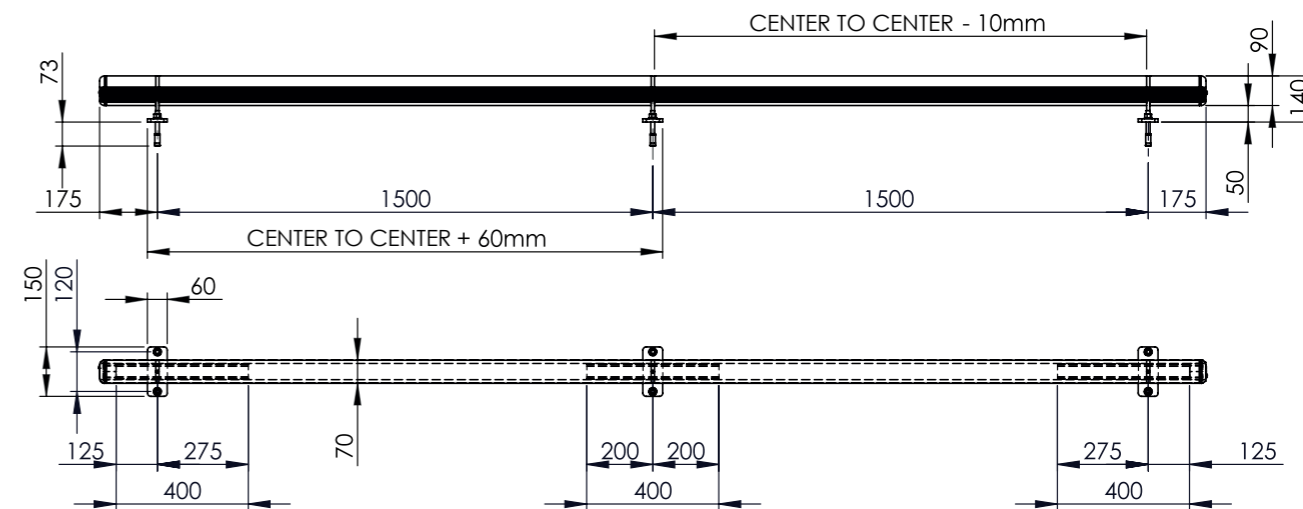
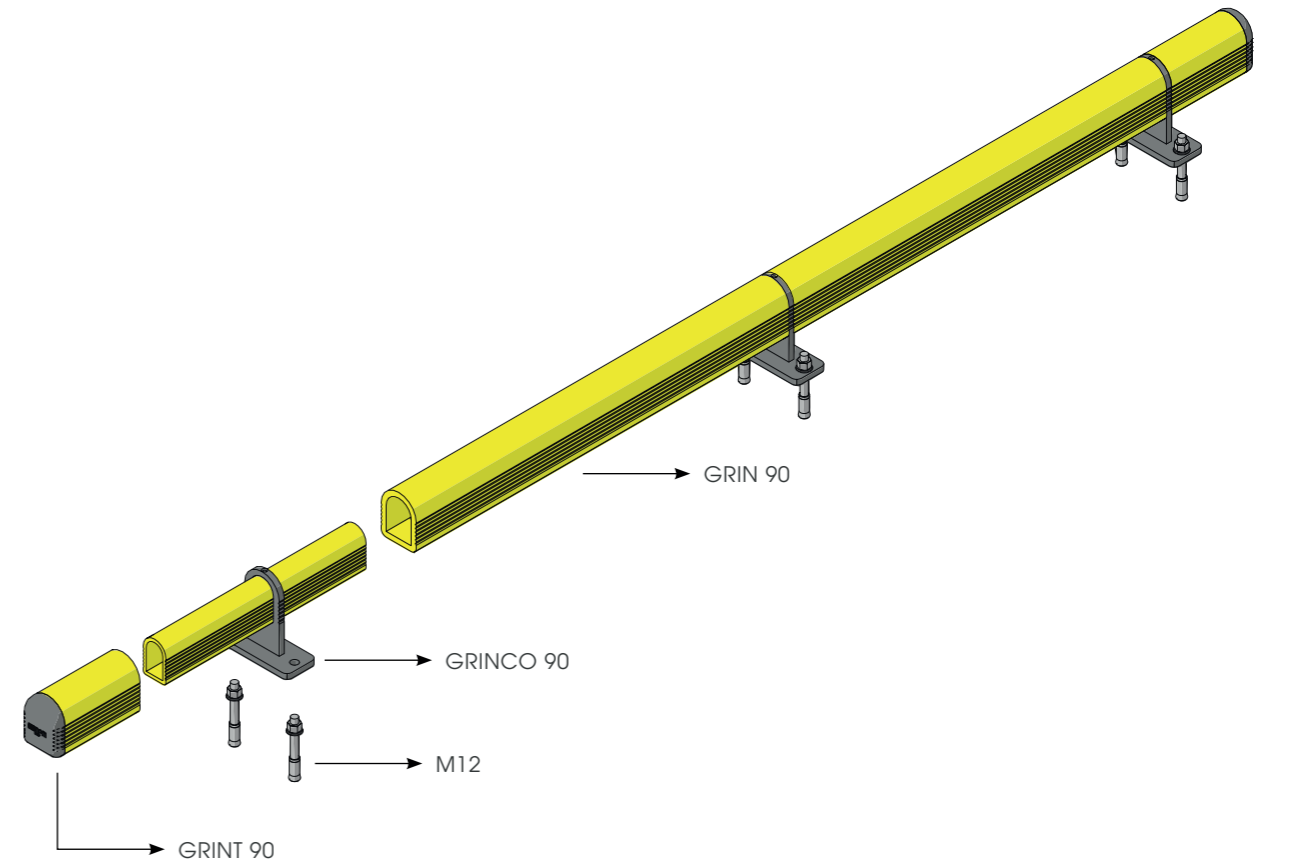

GRIN 150

GUARD RAIL CONTINUO
CONTINUOUS GUARD RAIL



IMPACT TEST PASSED
according to
AFNORNP P98-310

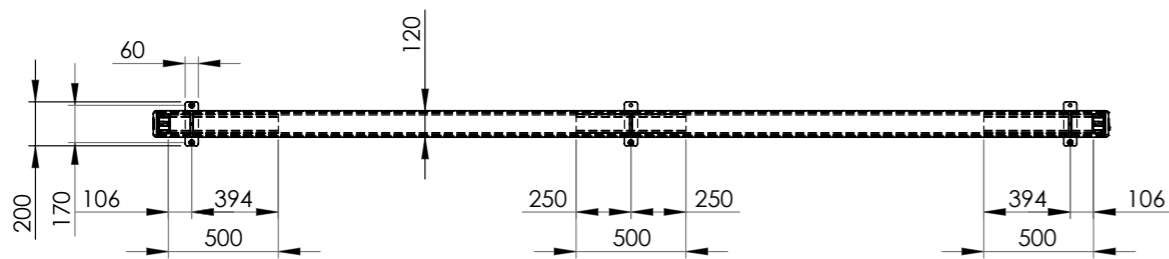
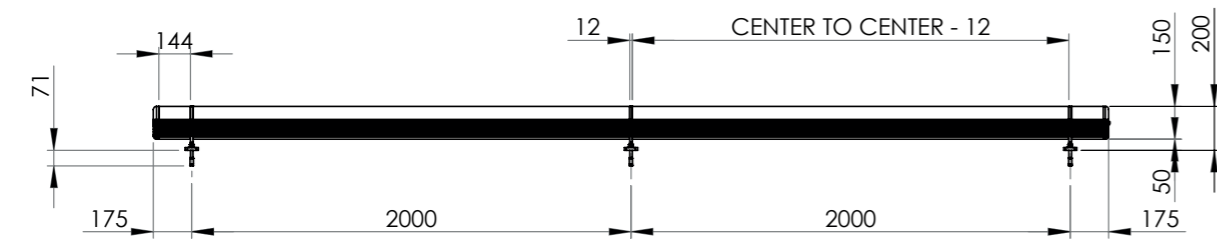
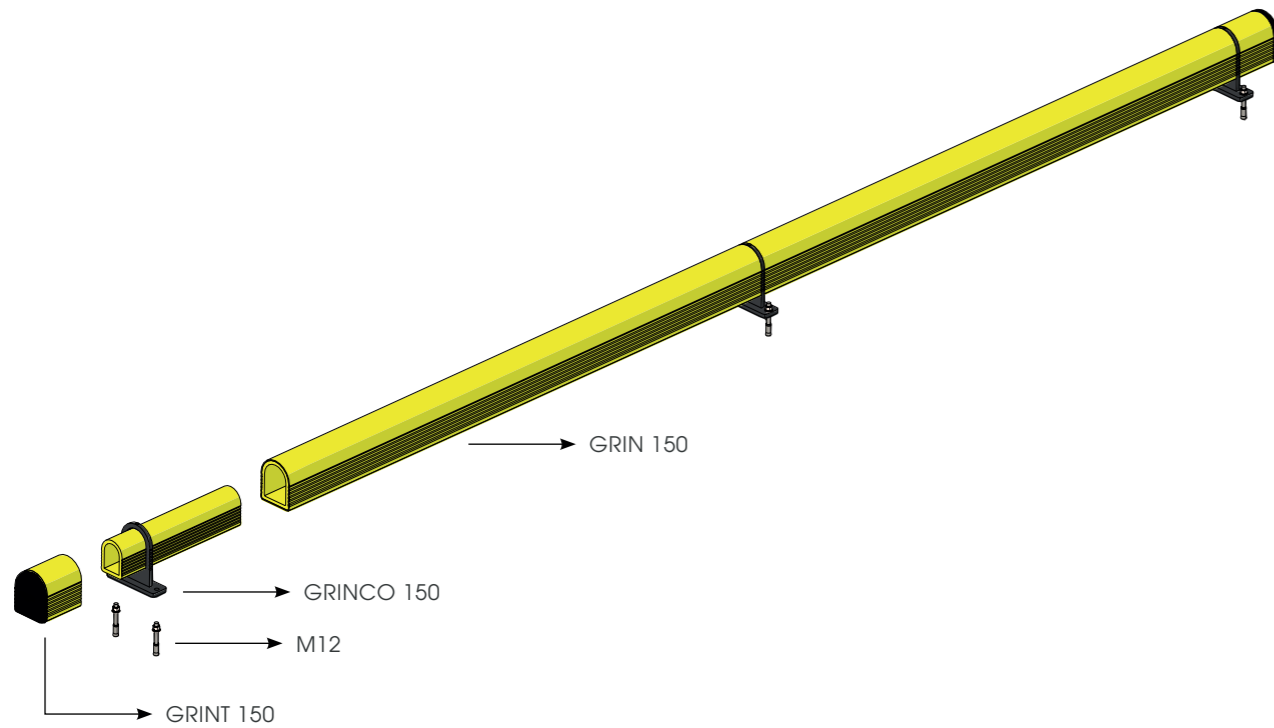

GRIN 90/150

ISTRUZIONI DI INSTALLAZIONE
ASSEMBLY INSTRUCTIONS

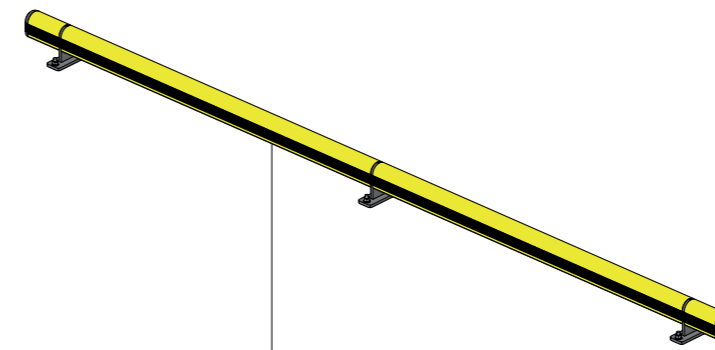
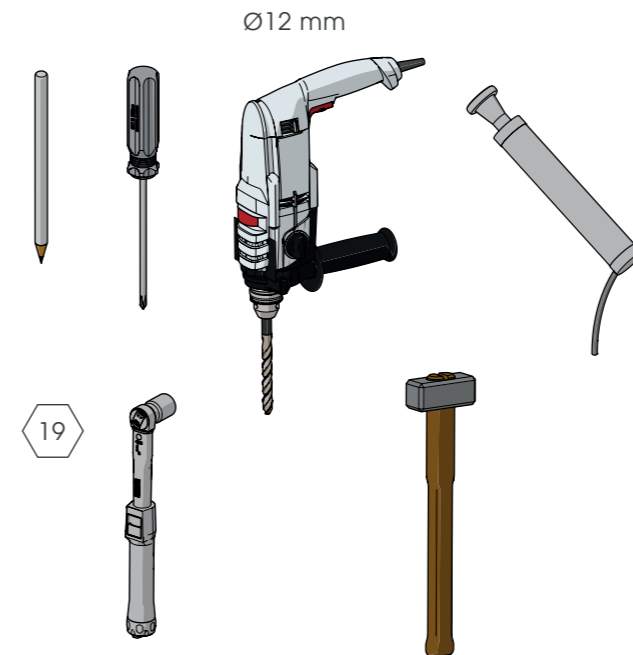

WARNING
The distance of installation depends on speed and weight of vehicle

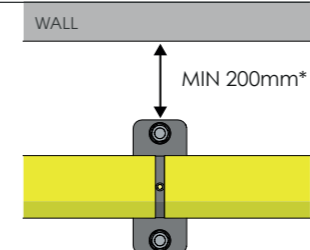

- 1
- 2
- 3
- 4
- 5

GRIN 90/150

ISTRUZIONI DI INSTALLAZIONE
ASSEMBLY INSTRUCTIONS

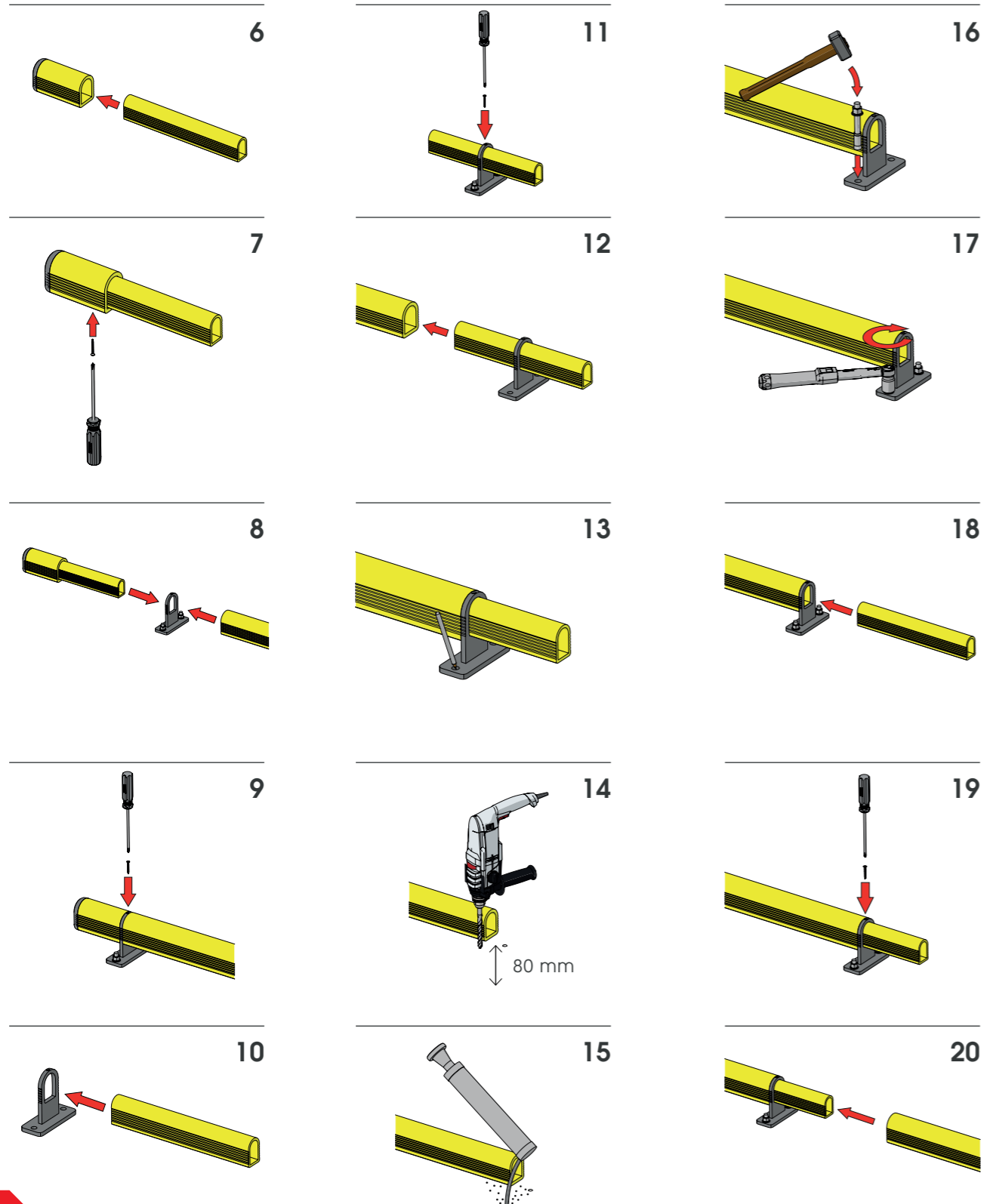

ROD PE 70

PALO PROTEZIONE
BOLLARD

